



### **OFFICE DELI SPECIFICATIONS**

The OFFICE DELI is comprised of three (3) units - Snack Unit (OD16S), Beverage Unit (OD8RD) and Entrée Unit (OD14F). Installation and setup of these units is explained in the next sections of this manual.

<b>Machine Description</b>	<b>Snack Unit</b>	<b>Beverage Unit</b>	<b>Entrée Unit</b>
<b>Model Number</b>	<b>OD16S</b>	<b>OD8RD</b>	<b>OD14F</b>
<b>Height (in)</b>	28.5	41	69.5
<b>Width (in)</b>	30.2	30.2	12.2
<b>Depth (in)</b>	28.5	28.5	28.5
<b>Volts (V)</b>	115	115	115
<b>Frequency (Hz)</b>	60	60	60
<b>Watts (W)</b>	100	350	100
<b>Current (A)*</b>	1.0	3.8	1.0

\* - Current draw varies depending on Operating Conditions and Load and are subject to change.

**The OFFICE DELI is designed for use in indoor conditions only. The recommended operating environment is 75° F and 40% RH.**

## OVERVIEW

This manual covers Installation, Setup, Programming and Service instructions. It is extremely important that this manual be read thoroughly prior to commissioning the OFFICE DELI unit in the field. This will ensure a satisfactory long-term performance.

The OFFICE DELI unit consists of three (3) separate cabinets that are installed together via mechanical means and connected via electrical connections to operate as ONE unit.

The Snack Vendor (OD16S) consists of three (3) trays. The first and second trays have 4 selections each (Tray 1 – B1 through B4, Tray 2 – B5 through B8). The third tray has 8 selections (C1 through C8). The top two trays are normally used for products that are wider such as chips, pastries etc. and the third tray is used for Confectionary items such as candy bars. The Snack Vendor (OD16S) also houses all the payment mechanisms and electronic Vending Machine Controller (VMC) on the right side of the cabinet, as shown in Figure 19. The payment mechanisms, electronic components (such as VMC) and transformer are installed on a vertical shelf that slides out for easy access. The connectors to connect the Beverage Unit (OD8RD) and Entrée Unit (OD14F) are also provided in this vertical shelf of the Snack Vendor (OD16S).

The Beverage Vendor (OD8RD) consists of Product Delivery systems consisting of a teeter-totter style mechanism and a vertical drop system. The Beverage Vendor also houses the removable Refrigeration System. The cabinet of the Beverage Vendor has a delivery system that has 6 selections for Cans and 2 selections for Bottles. The Cans are loaded in the chutes (D1, D2, D3, D4, D5 and D8) and the Bottles are loaded in Vertical Drop System columns (D6 & D7). The loading instructions are given in subsequent sections. The refrigeration system is installed at the bottom of the Beverage Vendor and there is a foamed separation between the cabinet interior and the refrigeration system. The installation, setup and functionality of the refrigeration system is explained in the section titled Refrigeration.

The Entrée Unit (OD14F) consists of 7 trays with 2 selections each (Tray 1 – A1 & A2, Tray 2 – A3 & A4, Tray 3 – A5 & A6, Tray 4 – A7 & A8, Tray 5 – A9 & A10, Tray 6 – B9 & B10, Tray 7 – C9 & C10).

## RECEIVING, INSPECTION, UNPACKING AND TESTING

After you have received your Office Deli, inspect all three individual vendor components. **Note:** Any damages that may have occurred during shipping must be reported to the delivery carrier immediately. Reporting damages and the seeking of restitution is the responsibility of the equipment owner. The factory is willing to assist you in this process in any way possible. Feel free to contact Seaga Customer Care with questions you may have on this process. Once you have your Office Deli located, we suggest that you keep this manual for future reference. Be sure to watch the video and follow the receiving inspection procedures.

The Office Deli Unit is placed on a wooden pallet and stretch-wrapped. Please exercise caution while cutting into the stretch-wrap with a sharp tool such as a utility knife, as it may cause scratch marks on the machine.

The Snack, Beverage and Entrée Units are boxed in three (3) separate cardboard boxes. The Snack Unit box is placed on top of the Beverage Unit while the Entrée Unit is located on the side of Snack/Beverage Units. After removing the stretch wrap, remove the Snack Unit and place it aside. **USE EXTREME CAUTION AS THE TOP OF THE BOX IS NOT ATTACHED TO THE BOTTOM OF THE BOX.** The top of both the snack and beverage units slide up for removal. Remove the Beverage Unit from its box and place it in the desired vending location. Remove the Snack Unit from its box and place it on top of the Beverage Unit carefully. Please use proper lifting and safety precautions while placing the Snack Unit on top of Beverage Unit. Remove the Entrée Unit from its box and place it to the left side of the Snack/Beverage Units.

Open all Unit doors and remove the packing materials. Keys can be found in the white envelope placed in the vend area of the Snack Unit. Remove the tape on the tray levers of the Snack and

Entrée units. Also remove the protective paper from under each helix coil as well as ties securing the ends of the helix coils during shipping. Remove all protective plastic from the window lenses.

Please plan on unpacking your Office Deli and setting up the machine for testing. This will give you the opportunity to become familiar with the machine and present a professional appearance on location. Set up for testing can be done exactly as if you were on location or you can improvise placing the units together to test them. This is entirely up to you, but we suggest the following scenario if you are going to improvise:

- 1.) Build up a platform next to the pallet by the Snack and Beverage units so that the Entrée unit is level with the other units. Then follow the setup instructions on your training DVD and in this manual.

Remember: at least two people are necessary to move any of the components of the Office Deli. Follow proper safety standard for lifting and working with electronic/refrigerated equipment.

### **INSTALLATION AT A LOCATION**

Once the machines have been unpacked and placed in their permanent location, installation involves both electrical connection and mechanical attachment. Tools required: Adjustable wrench and Philips screwdriver. For optimal installation, follow the order of connections as outlined below:

#### **1. Mechanical Connection between Snack and Beverage Units:**

The Snack and Beverage units must be screwed together for safety purposes. Two screws are provided in the white envelope found in the vend area of the Snack unit. Square the fronts and edges of the Snack and Beverage units. Open the Snack unit door and locate the two holes at the bottom of the unit. Insert both screws and tighten.

#### **2. Mechanical Connection between Entrée Unit and Snack/Beverage Unit:**

Two bolts and washers are provided in the white envelope found in the vend area of the Snack unit. Open the Entrée unit door and locate the two holes (upper and lower) on the interior of the right side of the unit. Line up the holes with the corresponding holes in the Snack/Beverage unit. Insert the bolts and washers and tighten with an adjustable wrench.

#### **3. Electrical Connection between Snack and Beverage Units:**

Remove the Styrofoam insert from the opening in the upper right corner of the beverage unit and save this for reinsertion. Open the Beverage unit door and locate the beverage main harness and refrigeration harnesses. See Figure 1. Insert harnesses through the opening up into the Snack cabinet, see Figure 2. Reinsert the Styrofoam piece for maximum insulation of the refrigeration unit. (You may have to remove a small piece out of the Styrofoam to accommodate the harnesses.)

Figure 1 – Beverage and Refrigeration Harnesses

Figure 2 – Inserting Beverage and Refrigeration Harnesses



Beverage and Refrigeration Harnesses

Beverage and Refrigeration Harnesses inserted up through Snack Unit

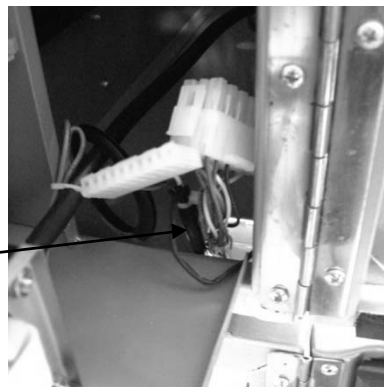

Connect the beverage main harness to Connector #5 and connect the refrigeration harnesses to the "Aux" connection on the VMC. Use an adjustable wrench to loosen the ground mounting nut and install the ground. Secure the nut back on the ground mounting, taking care not to over tighten. See Figure 3.

Figure 3 – Making Beverage Connections

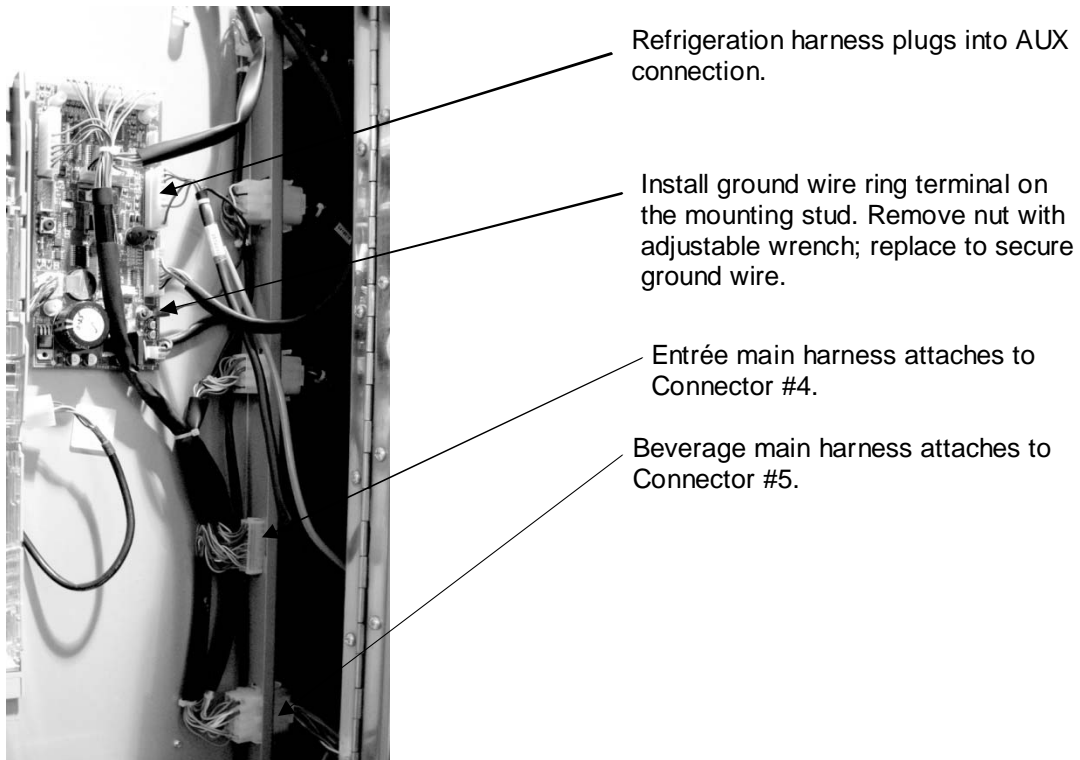

**4. Electrical Connection between Entrée Unit and Snack/Beverage Unit:**

Remove the third tray from the Entrée unit, by flipping up the tray lever (found on the right side of the tray), disconnecting the tray connector harness, and removing the tray from the unit. A hole in the rear of the Entrée unit will be exposed. Locate the entrée main harness and insert it through the hole. Replace the third tray. Move to the rear of the machine and insert the entrée main harness into the back of the Snack Unit. The harness will be deposited into the Snack cabinet. Connect the harness to Connector #4. See Figure 3 for the location of Connector #4.

After finishing the connections, plug the two main power cords to 115V, 15 A outlets. The outlets should not be controlled by a light switch. Once power is established, the LED display will first read Software Version and then change to "00.00". The refrigeration system will also start running (fans followed by compressor after short delay).

Figure 4 – Connecting the Snack, Beverage & Entrée Units

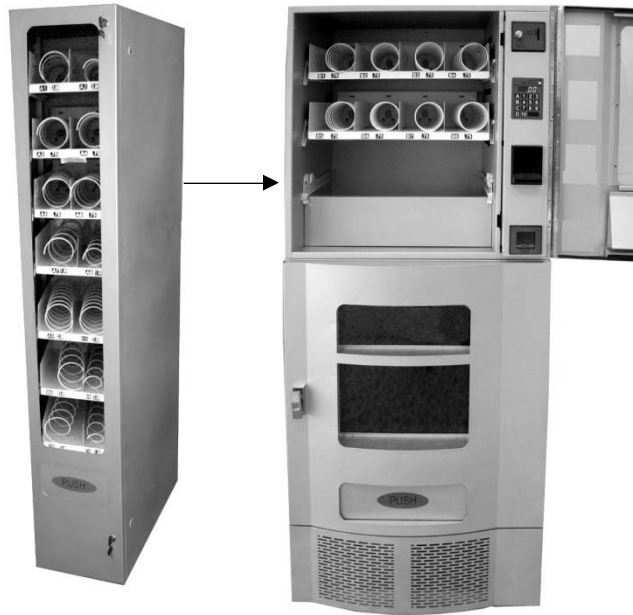
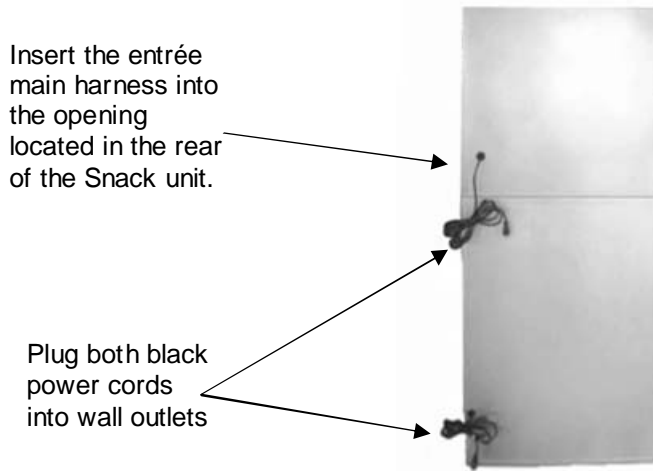

Figure 5 – Connecting the Snack, Beverage & Entrée Units



**LOADING PRODUCT TRAYS**

Open the front door of vendor, and lift up the plastic lock lever on the right side of the tray to unlock. Holding the lever up, grasp the tray and lift the front of the tray slightly and pull forward. The tray will slide out and then tilt down to make loading of products easier. Load only one product tray at a time (See Figure 6).

Figure 6 – Slide-out product trays

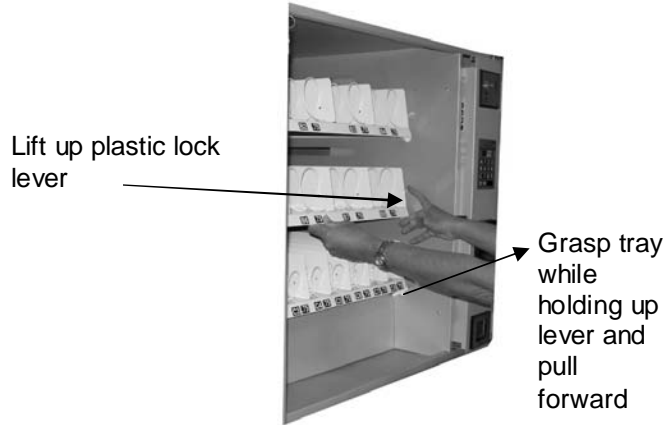

1. To Load Product in Snack Unit and/or Entrée Unit:

- a. Pull the desired product tray all the way forward. Product tray will tilt down.  
**Note:** Pull out only one (1) product tray at a time
- b. Place product in proper size helix coil.  
**Note:** Bottom of product must rest on the product tray and not on the Helix Coil. Load each column from back to front.  
**Note:** Fill all product trays fully; do not leave any spaces behind or between items
- c. Once product tray is fully loaded, lift and push it back in.

Repeat steps a through c until all product trays are fully loaded. Special Note: We suggest that you always partially fill the tray with product and perform at least five (5) test vend. Test vend. can be performed easily by entering Service Mode and running the “tE” function -Individual motors testing.

**PRODUCT LOADING**

**Snack Unit**

Wide products such as Chips bags etc. are loaded in Tray 1 and Tray 2. Narrow products such as Candy bars are loaded in Tray 3. See Figure 7.

Figure 7 – Loading Product

Correct – load product between Helix Coils, resting on the product tray

Helix Coil

Product Tray



Incorrect

## HELIX COIL LOCATION ADJUSTMENT

If you are required by a location to vend a product that is not on your Plan-O-Gram, you may need to order a different helix coil and install it. To replace a helix coil:

1. Remove the Helix Coil from the Coil Driver by lifting the back of the helix coil up off the coil driver. You will need to move the bottom of the helix coil clear of the coil driver to completely remove the helix coil. See Figure 8.
2. Align the new helix coil end with the front of the tray, which gives the helix coil better contact with the product. The position of the helix coil in the coil driver is adjustable to assist you in aligning the new helix coil at the front of the tray. See Figure 8.

This Coil adjustment can be done for all the Selections on Snack and Entrée units.

Figure 8 – Removing and Aligning a Helix Coil

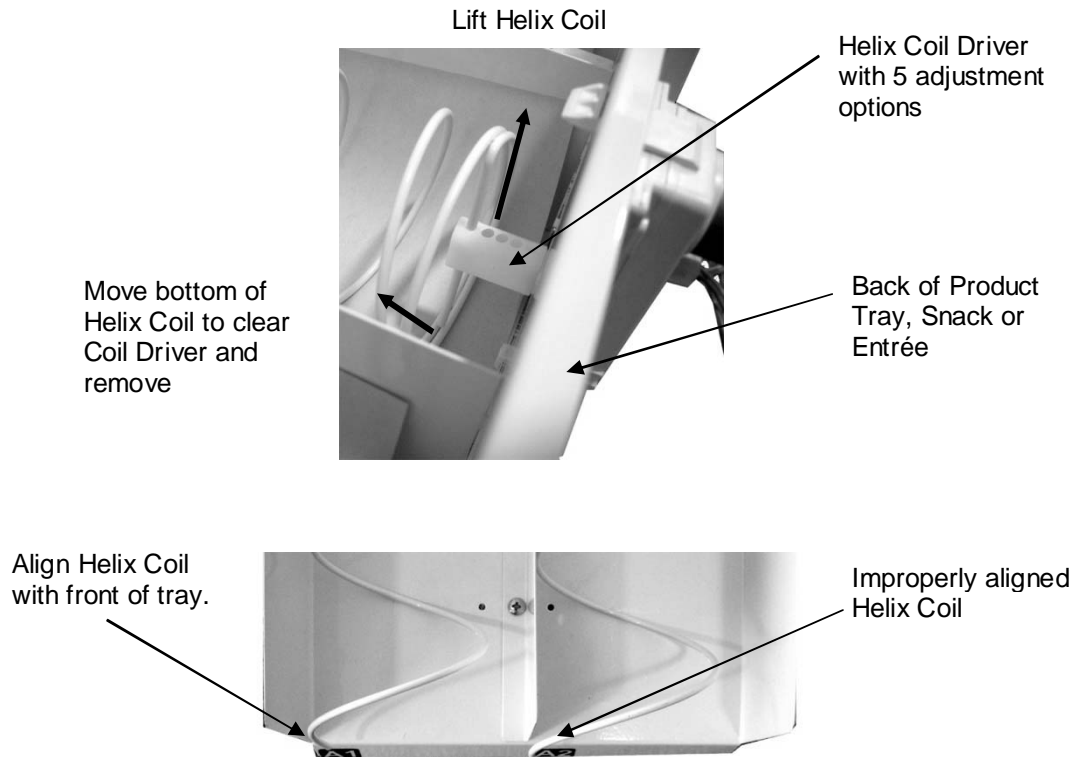

## Beverage Unit

The cans are loaded in D1, D2, D3, D4, D5 & D8. Selections D6 & D7 can be loaded with bottles. These instructions are also available for quick reference on a yellow decal inside the unit. See Figure 9.

Figure 9 – Loading Beverage Unit

### Selections D1, D2 and D3

There are two chutes for each selection.

1. Load 2 cans only from the bottom chute.
2. Load cans from the top chute until completely full. Upon filling top chute, proceed to fill bottom chute, leaving one less can in this chute. This assists with the gravity method of vending.

### Selections D4, D5 and D8

There are two chutes for each selection.

1. Load 5 cans only from the bottom chute.
2. Load cans from the top chute until completely full. Upon filling top chute, proceed to fill bottom chute.

### Selections D6 and D7 Vertical Product Columns

- 1.) For bottles, place bottom of the first bottle against the front of the column by the Sold Out Switch. Place the second bottle to the rear of the column, touching the cap of the first bottle. See illustration at right.
- 2.) Finish loading to the top of the column, making sure bottles are perfectly horizontal and not tilted or skewed in the column.
- 3.) To adjust the rear spacer, grasp firmly and lift up and move forward or rear, as required, so that the rear spacer is touching the rear bottle.

Note: There are many variations of packaging among the beverage brands. The instructions above are meant to be a guideline. If you have packaging that isn't mentioned or shown, experimentation will be necessary for a proper vend.

### Selections D4, D5, D8

Chute #1 Vends 1<sup>st</sup>

Chute #2 Vends 2<sup>nd</sup>

Selections D1, D2, D3

Chute #3 Vends 1<sup>st</sup>

Chute #4 Vends 2<sup>nd</sup>

### Product Chutes

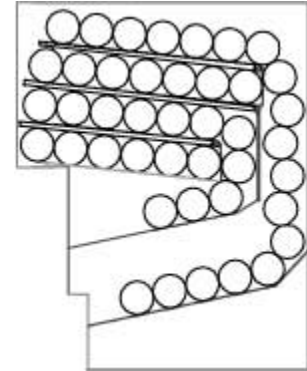

### Vertical Product Column

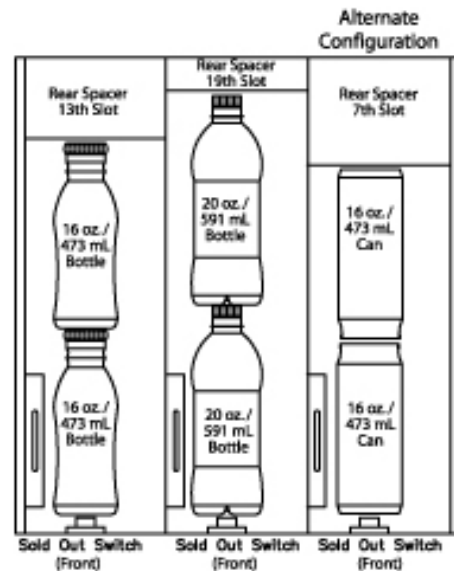
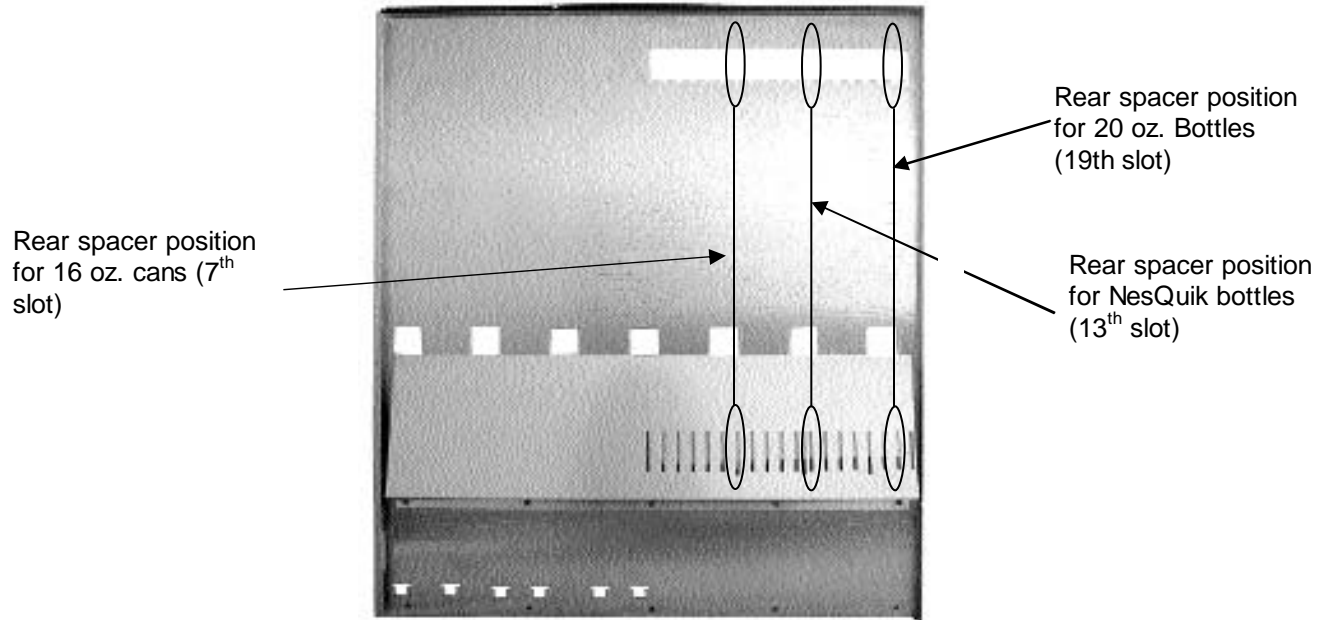

Figure 10 – Vertical Column Components



***You may need to adjust due to product height variance.***

Rear Spacer



Vertical column components are continued on next page.

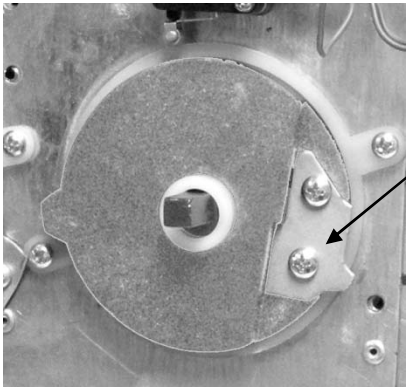

Bottle Cam shown installed on auger. Motor and brackets removed.

Bottle Shim shown Installed

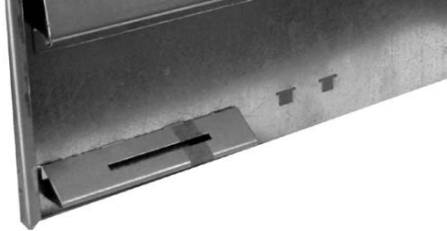

Bottle Shim

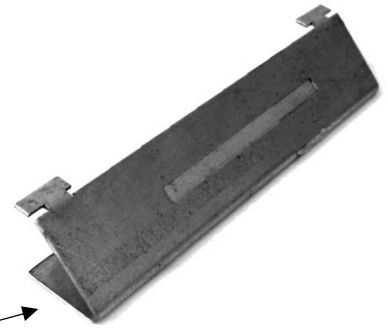

Specialty kits are available for Frappuccino and Red Bull as well as oddly shaped packaging, but are not included. Contact Seaga's Customer Care Team to order, if needed:

Figure 11 – Removing Vertical Drop Motors and Auger System

Remove two screws holding in motor/bracket.

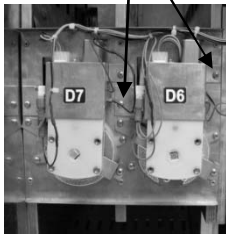

If replacing motor, unplug wire harness and re-assemble.

If replacing auger, continue with instruction to right...

Remove auger for replacement.

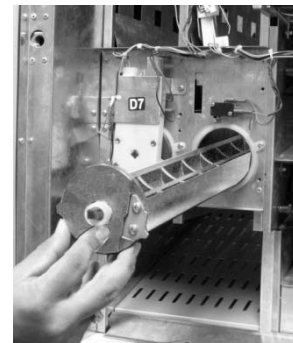

The Beverage unit does not ensure FIFO (first in first out). So whenever fresh beverages are loaded (usually from the upper chutes) it is likely that the lower chutes of the can unit may still be holding some older cans for a period of time. Although beverages have reasonably good shelf life, we recommend that the Beverage unit be emptied once every 30 days and reloaded, so that a forced product rotation takes place.

### Entrée Unit

The appropriate loading procedure is dependent on the type of product you will be vending, as entrée items have different sizes and shapes.

**Note:** The size of the item being vended must be larger than the Helix Coil, but smaller than the column, to vend correctly. Never force an oversized item into the helix coil or column, nor attempt to vend an item that is smaller than the helix coil as this will create problems and deter customers. The

Entrée vendor ensures FIFO (First in first out) of product stock rotation. This is not so in the case of the Beverage unit.

In Figure 12 below, the chart identifies the helix coils (4 space through 8 space) that are shipped to you for each selection in the Entrée unit. The default price setting is also listed.

To present your product in as attractive and professional manner as possible, do not load damaged items and make sure that the items are facing forward for easy identification by your customer. Depending on shape of product, the orientation in the helix coil may change for best fit.

Figure 12 – Entrée Unit Loading

<b>HELIX COIL SPACING BY TRAY</b>		
<b>Tray 1</b>	<b>A1 (\$2.00)</b>	<b>A2 (\$2.00)</b>
	<b>4-SPACE</b>	<b>4-SPACE</b>
<b>Tray 2</b>	<b>A3 (\$0.75)</b>	<b>A4 (\$0.75)</b>
	<b>4-SPACE</b>	<b>4-SPACE</b>
<b>Tray 3</b>	<b>A5 (\$0.75)</b>	<b>A6 (\$0.75)</b>
	<b>8-SPACE</b>	<b>5-SPACE</b>
<b>Tray 4</b>	<b>A7 (\$1.50)</b>	<b>A8 (\$1.50)</b>
	<b>4-SPACE</b>	<b>4-SPACE</b>
<b>Tray 5</b>	<b>A9 (\$2.50)</b>	<b>A10 (\$2.50)</b>
	<b>8-SPACE</b>	<b>8-SPACE</b>
<b>Tray 6</b>	<b>B9 (\$3.00)</b>	<b>B10 (\$3.00)</b>
	<b>8-SPACE</b>	<b>8-SPACE</b>
<b>Tray 7</b>	<b>C9 (\$3.00)</b>	<b>C10 (\$3.00)</b>
	<b>4-SPACE</b>	<b>4-SPACE</b>

**ENTRÉE UNIT TRAY ADJUSTMENT**

Entrée Unit trays are provided with width adjustment for each selection. To adjust the width of a selection in your Entrée Unit:

1. There are three (3) holes on the front of the tray for the Divider fastener and three (3) rectangular openings on the back of the Tray for Divider positioning as shown in Figure 13.
2. Place the product in the Coil for reference and adjust the Divider to support the new product and line up the mounting hole. Products should not fit too tightly in the column. The product should not be touching the divider when placed in ready-to-vend position in Helix Coil.
3. Once the location of Divider is determined, line up the end tab on the Divider with the rectangular opening on the back of the tray as shown in Figure 13.
4. Complete the installation by securing the front of the Divider with a fastener in the mounting hole. See Figure 13.

Figure 13 – Entrée Unit Divider

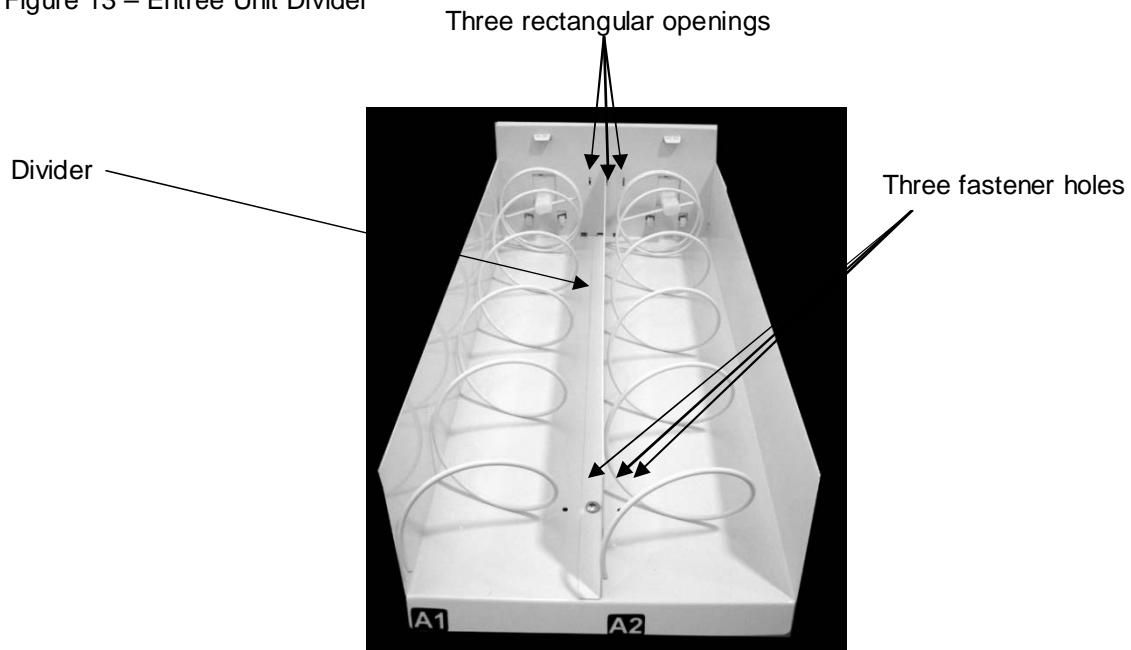

Note: This adjustment will result in reduction of width in the adjacent selection. Please make sure the product to be vended from the adjacent selection is appropriately placed as per loading instructions as described in “Product Loading” section.

### KEYPAD AND LED DISPLAY

The Keypad is touch sensitive. Light pressure will be necessary to activate each number or letter. The Keypad is used by the customer to make their selection, and by the operator to set and test many functions of the Office Deli. Note: The keypad and LED Display are 2 separate components, though they appear as one streamlined piece.

Figure 14 - Keypad

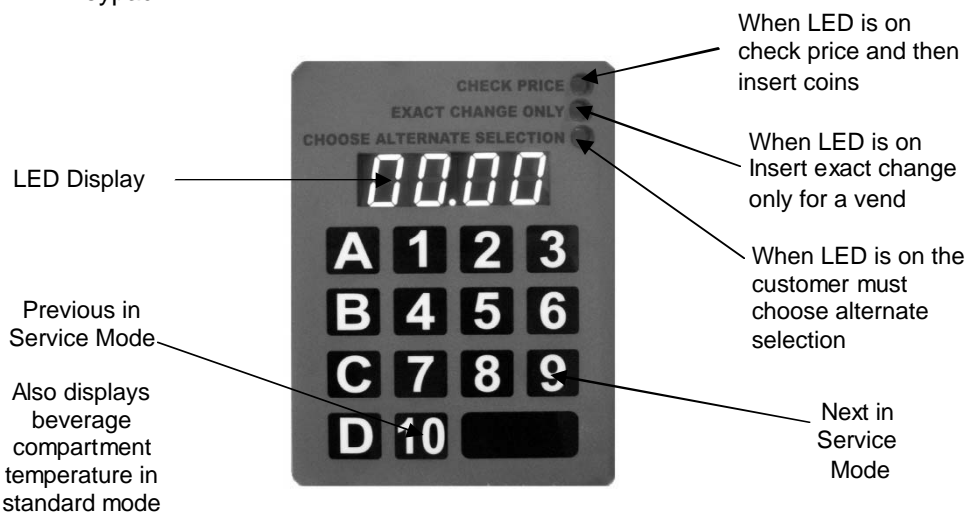

The LED Display shows the customer the amount of money entered into the vendor, and the cost of their selection. It shows the operator the Service Mode function for setting and testing the various functions of the vendor.

## PROGRAMMING

Unlock and open the Front Door to access the VMC, and enter Service Mode by pressing the MENUS Button. (Fig. 15)

Figure 15 - MENUS Button

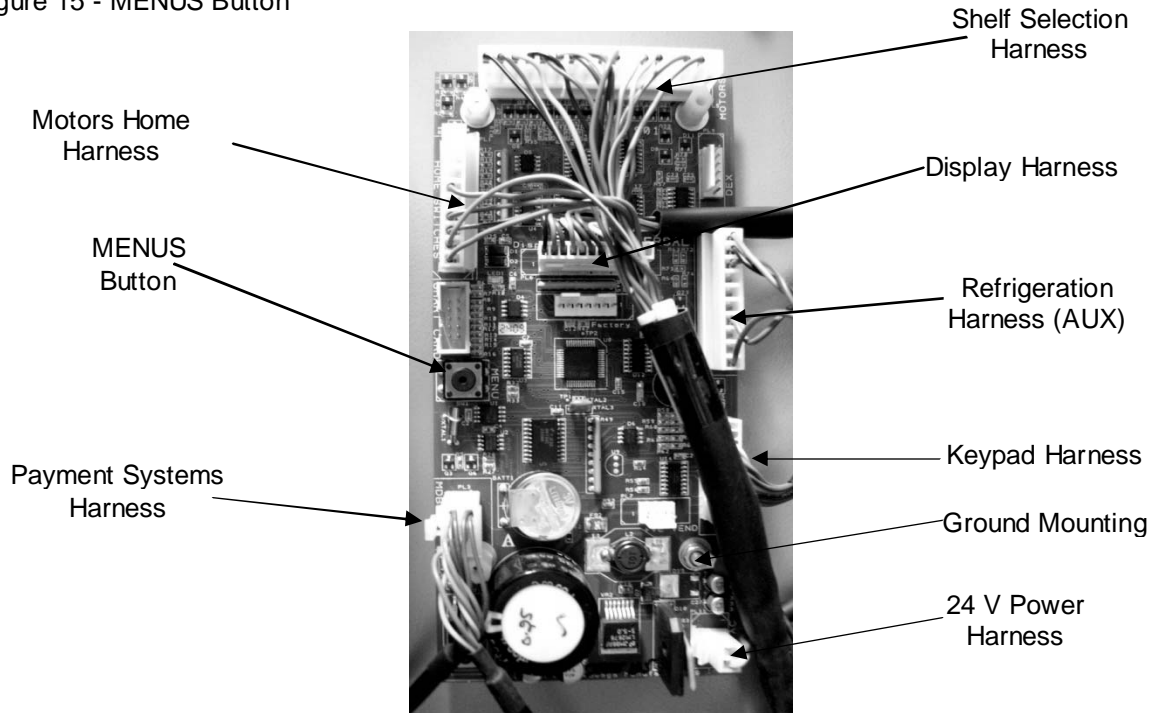

## BASIC OPERATION

The following display formats are used:

	Display when Active	Exact LED	Check Price LED	ALT SEL LED
Standard Operation, no credit available	00.00			
Standard Operation, some credit available	00.01 – 99.95			
After Pressing a selection, if there is no credit, or the credit is less than the selection's price, the price of the selection is displayed for a few seconds, before reverting to one of the above credit display formats. (If a coin or other payment is made, the display reverts immediately)	00.05 – 99.95		ON	
Free Vend Mode (all prices set to zero)	FrEE			
If a selection is out of stock when a selection is pressed – this is displayed for a few seconds	Sold Out (as two successive messages)			ON
All Items out of stock	Sold Out (as two successive messages repeated)			
Machine Out Of Order	Out oF Ordr (as 3 successive messages)			
During a Vend (Progress bar, 1, 2, 3 and 4 dashes)	- - - -			
Consumer presses Coin Return when Force Vend is ON, change is not permitted	SEL			
Exact Change required (MDB Changer enabled)		ON		
Temperature Display (if control is enabled) – press the <b>10</b> button to display	nnC or nnF			
Timed Lockout or H & S lockout	OFF			
Refrigeration System Error: Note Error Code 70 in Error Codes section of this manual.	Errt			

## SERVICE MODE

The operation of the machine can be adjusted by entering Service Mode, pressing the MENUS button on the VMC circuit board and accessing the appropriate operation. Price setting, audit display and operating modes can be read and adjusted from here. The user can also perform tests on the machine through this mode. Note: any Credit will be cancelled on entry to Service Mode.

1. Enter Service Mode by pressing the MENUS Button on the VMC Circuit board.
2. Each Service Code can then be accessed using the **9** (Next) and **10** (Previous) buttons to scroll through the menus in sequence:

1. AUDIT	Displays	Au.--
2. PRICE SETTING	Displays	PS.--
3. TEST MODE	Displays	tE.--
4. CONTROL WORD	Displays	Ct.** <small>Where ** is the current value</small>
5. SOUND On/Off	Displays	So.0* <small>Where * is the current state (0 or 1)</small>
6. DISPLAY ERRORS	Displays	Er.--
7. CLEAR ERRORS	Displays	CE.--
8. SET CLOCK	Displays	CL.--
9. MDB PAYMENT DEVICES	Displays	Pd.** <small>Where ** is the current value</small>
10. HOME & COUNT MOTORS	Displays	Ho.** <small>Where ** is the last count of motors</small>
11. TEMPERATURE SETTING	Displays	tS.** <small>Where ** is the current state</small>
12. END MENUS	Displays	En. --

## AUDIT

Within Service Code Au (Audit) readings can be taken from the Display with regards to cash taken, and number of products vended. The following details can be obtained on the Display.

- 1 Total Cash IN : (up to 999999.99)
- 2 Total Product Sales Value: (up to 999999.99)
- 3 Total Count of Free Vend Tokens : (up to 49999)
- 4 Total Coins IN : (up to 999999.99)
- 5 Total Cash Out : (up to 999999.99)
- 6 Total Bills IN : (up to 999999.99)
- 7 Total Card Payment : (up to 999999.99)
- 8 Total Manual Dispensed amount: (up to 999999.99)

### **Selection** (alpha then numeric)

Display the total number of individual vends of that selection (up to 49999)

Press the Scroll buttons (9 and 10) repeatedly until the LCD Displays Au.

*You are now in Audit Mode*

**Press Selection Button 2 to reveal the total sales value      Displays \*\*\*\* and \*\*.\*\*. Etc.**

Values are displayed in parts as \*\*\*\* then \*\*.\*\*. for values up to 999999.99  
and \*\* then \*\*\*\* for non decimal values up to 49999.

Note: Decimal values “roll-over” from 999999.99 to 0.00  
Integer counts “roll-over” from 49999 to 0

**NOTE: FOR SECURITY PURPOSES, TOTALS DO NOT ZERO OUT AFTER EACH TIME YOU DISPLAY TOTALS.**

### **PRICE SETTING**

Price Setting is performed by selecting Service Code PS.

1. Press the Scroll buttons (**9** and **10**) repeatedly until the LCD Displays PS.--

*You are now in Price Setting Mode*

2. Make a selection (Alpha then number) to display the current price  
Displays the row and column and then \*\*. \*\*
3. Using the numeric keys, set the price for this selection (the **10** button is interpreted as a zero) by entering 4 digits. The display will then revert to PS when this is complete.

*Prices may be set from 00.00 to 99.95.*

4. Press two Alpha selections (Ex: “A” then “A”) then a number (price) to set the price for an entire tray at once. Pressing three Alpha selections (AAA) allows all the prices to be set in one operation.

### **TEST MODE**

1. Press the scroll buttons (**9** and **10**) repeatedly until Displays tE.--

In Test Mode, making a selection (Alpha then numeric) will operate the selected motor.

Press selection button 1 for a single test vend on ALL selections.  
Press selection button 2 to test the positive vend sensor (if enabled).  
Press selection button 3 to test Relay output 1 (Compressor Cycle).  
Press selection button 4 to test Relay output 2 (Defrost).

Note : You must be in Test mode to manually empty the coin changer.

**WARNING : THIS MENU OPTION DOES NOT TIME OUT AFTER 30 SECONDS**

### **CONTROL WORD**

1. Press the Scroll buttons (**9** and **10**) repeatedly until the LCD Displays Ct. \*\*  
(where \*\* is current value)  
*You are now in Control Word Setting*
2. Press Selection Button **1** to **4** to change the control word Displays Ct. \*\*

*The control word is now set*

**\*\*\*RECOMMENDED CODE: 2**

**The control word options supported are :**

<b>Code</b>	<b>Multivend</b>	<b>Forced Vend</b>
1	No – single vend	No
2	Yes - multivend	No
3	No – single vend	Yes
4	Yes - multivend	Yes

**SOUND (ON/OFF)**

1. Press the scroll buttons (**9** and **10**) repeatedly until Displays So.00
2. Press Selection Button **1** to toggle the setting Displays So.01
3. Press any other Button to exit to the next menu option

A value of 1 enables the sound, 0 disables the sound.

**\*\*\*RECOMMENDED CODE: 1 (ON)**

**DISPLAY ERRORS**

1. Press the scroll buttons (**9** and **10**) repeatedly until Displays Er.- -

In this mode, press any selection button (other than **9** or **10**) to display error codes in sequence, shown as Er.nn where nn is the error number.

**ERROR CODES**

<b>Error Code Number</b>	<b>Fault detected</b>	<b>Hard/Soft fault</b>	<b>Action</b>
01 .. 60	Motor A1 .. F10 respectively	Soft	Repair/replace motor/home switch
70	Refrigeration Error	Hard	Check connection to temperature sensor, check connection to Aux Terminal on main control board
80	Coin Changer fault	Hard	Repair/replace coin changer or disable the coin changer
81	Change giver Out Of Change	Soft	Fill Tubes
82	Error in credit value	Soft	None
85	MDB Bill Reader fault	Hard	Repair/replace Bill Reader or disable the bill reader
90	MDB Card Reader fault	Hard	Repair/replace Card Reader or disable the Card reader
91	Error in Bill credit value	Soft	None

**Soft Errors** – unit will continue to operate though failed motors will show as “Sold Out” and be blocked from operation if selected.

**Hard Errors** – the unit is put out of service. This mode can only be cleared via the menus.

**CLEAR ERRORS**

1. Press the scroll buttons (**9** and **10**) repeatedly until Displays CE.- -

In this mode, press any selection button (other than 9 or 10) to clear all errors – confirmed with a “CLr” display.

**SET CLOCK**

1. Press the scroll buttons (**9** and **10**) repeatedly until Displays CL--

In this mode, press the selection buttons listed below to set the current time, date and day of week:

1. Time – displayed in a 24-hour clock format as **HH.MM** Press 4 digits in turn to set the time.
2. Date – displayed as **DD.MM** Press 4 digits in turn to set the date and month.
3. Year – displayed as **y-YY** Press 2 digits in turn to set the year (00 – 99).
4. Day of Week – displayed as **d-- n** enter a single digit to set the day of week (1 = Sunday, 2 = Monday ... 7=Saturday)

In this mode, press the selection buttons listed below to set the unit Serial Number and Asset Number (4 digits only):

- A Asset Number : Press 4 digits in turn to set the value.
- B Serial Number : Press 4 digits in turn to set the value.

**MDB PAYMENT DEVICES**

1. Press the scroll buttons (**9** and **10**) repeatedly until Displays Pd. \*\*  
(where \*\* is current value)  
*You are now in Payment Device Setting*

2. Press a numeric selection (**1 – 7**) to change the value Displays Pd. \*\*  
*The Payment Device code is now set*

**\*\*\*RECOMMENDED CODE: 3**

**The payment device values supported are :**

Value	Coin Changer	Bill Validator	Card Reader
1	ON	OFF	OFF
2	OFF	ON	OFF
3	ON	ON	OFF
4	OFF	OFF	ON
5	ON	OFF	ON
6	OFF	ON	ON
7	ON	ON	ON
8	OFF	OFF	OFF

**HOME AND COUNT MOTORS**

1. Press the scroll buttons (**9** and **10**) repeatedly until Displays Ho.nn

In this mode, press and key other than **9** or **10** to home and count the Motors. The LED display will show the row/column being homed, and each motor will activate in sequence – each helix coil will turn and each can and bottle motor will rotate. If products are loaded, one of each product will be vended. If the circuit board is reading the motors correctly, a cumulative count of motors is displayed on the LED. If there is a circuit/motor problem on a particular selection, "Err" will appear on the LED after each faulty selection number.

**IMPORTANT: THE MOTOR HOME AND COUNT FUNCTION SHOULD NEVER BE USED WHEN PRODUCTS ARE LOADED AND THE DOORS ARE CLOSED. ALL SELECTIONS WILL VENDOR IN SEQUENCE AND SERIOUS PRODUCT JAMS WILL OCCUR.**

**TEMPERATURE SETTINGS**

1. Press the scroll buttons (**9** and **10**) repeatedly until Displays **tS.\*\***  
\*\* shows the current state

This menu option allows the zone temperature settings to be displayed and modified.

The first digit is the ON/OFF state: 0 means that the zone control is OFF  
1 means that it is ON

The second digit shows the temperature scale currently in use:  
F means Fahrenheit  
C means Celsius

- Examples:
- |              |   |
|--------------|---|
| <b>tS.1F</b> | Zone control is ON, temperatures in Fahrenheit  |
| <b>tS.1C</b> | Zone control is ON, temperatures in Celsius     |
| <b>tS.0F</b> | Zone control is OFF, temperatures in Fahrenheit |

In this mode, press the selection buttons listed below to set mode and temperature limits

- 1 Turn the Zone **ON**.
- 2 Turn the Zone **OFF**.
- 3 Set the **LOWER** Limit control temperature - Press 2 digits in turn to set the temperature (00 - 99). Any other alpha key will cancel the operation. Lower limit - minimum 1° C (34F) maximum 11° C (53° F).
- 4 Set the **UPPER** Limit control temperature - Press 2 digits in turn to set the temperature (00 – 99). Any other alpha key will cancel the operation. Upper Limit - minimum 3° C (37° F) maximum 13° C (56° F). Upper limit to be set at least 2° C above the lower limit.
- 5 Select Celsius (Centigrade) temperature display.
- 6 Select Fahrenheit temperature display.

**END MENU DISPLAY**

END Menu

Displays En.--

Exit Service Mode by selecting the END option and press any key other than 9 or 10, or the menu function will end automatically if there is no activity for 30 seconds.

## REMOVING PRODUCT TRAY

Push up the plastic cam lock lever on the right side of tray (Fig. 16). Grasp the Product tray under both the front corners, and lift the front of the tray slightly and pull the tray out completely. Remove the Wiring harness connector located on the inside right-hand side of the tray.

Figure 16 – Product tray cam lock lever  
(Shown with tray removed)

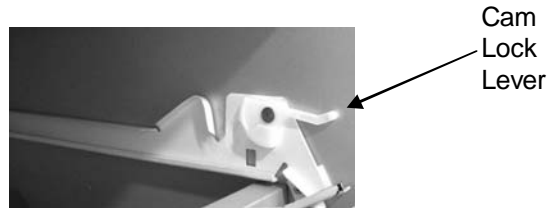

## VEND MOTORS

Each Selection is vended by the action of the Vend Motor. The Vend Motors are clipped onto the rear of each Product Tray. In the rare event of a jam, a Vend Motor may need to be returned to its home position.

Figure 17 – Vend Motor

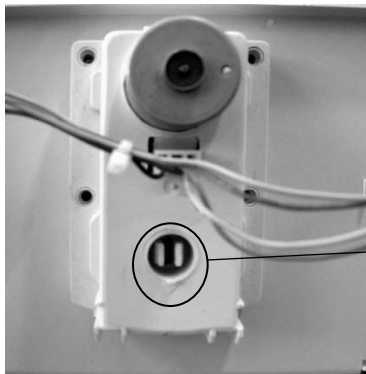

Vend Motor is home  
when tab on shaft area  
lines up with arrow on  
motor housing

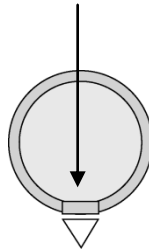
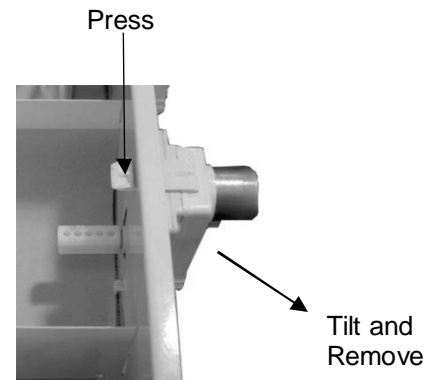

Figure 18 – Vend Motor Removal



1. To “Home “ a Vend Motor
  - a. Unlock and open the Front Door to access the Circuit Board, and enter Service Mode by pressing the MENUS Button
  - b. Cycle through the Service Mode until the Display Reads “tE”
  - c. Enter the letter and number of the motor you wish to home. The motor will rotate to its home position.
  
2. To Remove a Vend Motor
  - a. Unlock and open the front door
  - b. Unlock Product Tray and pull it out fully while keeping it level
  - c. Lift Product tray to release from the Track and pull it out

**Caution:** The Product Tray Wire Harness will need to be unplugged prior to complete removal of the product tray. The wiring harness is plugged into the slide-out shelf in the Snack unit or in the back of the cabinet in the Entrée unit.

- d. Remove Helix Coil from the driver by lifting the front end of the Helix Coil up with one hand pinching the lugs of the shaft. Push the shaft through the back of the vend motor, freeing up the helix coil/driver/shaft assembly for removal.

**Note:** This operation is more difficult with smaller Helix Coils.

- e. Depress the top tab on the Vend Motor, tilt the Vend Motor toward the back of the tray, and lift the vend motor free.

- f. Disconnect Wires of the Vend Motor, paying close attention to the orientation of the motor plug wire connector.
- g. Replace Vend Motor by repeating above steps in reverse order, making sure you plug the vend motor connector in the same way it was originally. **Note:** Failure to do so may result in vend motor failure.

## PAYMENT SYSTEM

### COIN CHANGER

The Coin Changer receives and returns change to customers. The Coin Changer will accept Quarters, Dimes, and Nickels. The Coin Changer can be set to accept the new Golden Dollar. Once all coin tubes reach the required inventory levels, all other coins will be routed into the coin overflow tray. All Golden Dollar coins will always be routed to the coin overflow tray.

### LOADING CHANGER

As change is given to the customer in coins only, it is recommended that you initially load the tubes completely full when setting up your vendor and that you do not allow your vendor's coin inventory to drop below three-quarters full. In order for your VMC to keep an accurate coin inventory, enter Service Mode, scroll through to "tE", and load coins in through the front coin slot, as if you were inserting money to purchase items. Once the coins start dropping into the coin box, that means that the coin tubes are full and the VMC has an inventory of coins stored and will calculate transactions accordingly. This is also known as priming the changer.

### COIN RETRIEVAL

Coins can be retrieved from the vendor in three (3) ways, the Coin Box, Manual Coin Retrieval Button, and the Coin Return Button. The Coin Box sits below the vertical shelf. The Coin Box holds all accepted coins except for Quarters needed to maintain inventory in the Quarter Tube. (Some overflow may occur) The Manual Coin Retrieval buttons are located on the upper portion of the changer and are labeled A, B, C, D and E. When in Service Mode, in the "tE" function, pressing a manual coin retrieval button will dispense one [1] of the selected coins.

Figure 19 – Vertical Shelf and Components

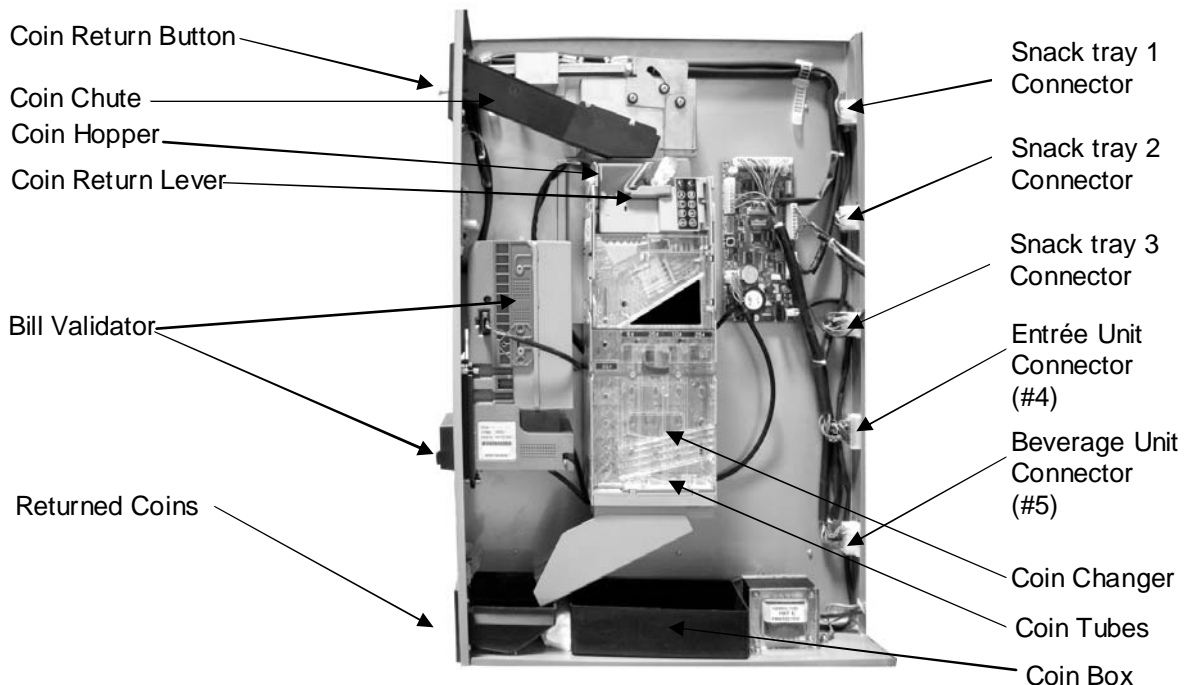

The Coin Return Button pushes the Coin Return Lever, which returns inserted coins to the customer.

**Note:** If Force Vend is on, pressing the Coin Return button will not return coins.

Figure 20 - Coin Changer

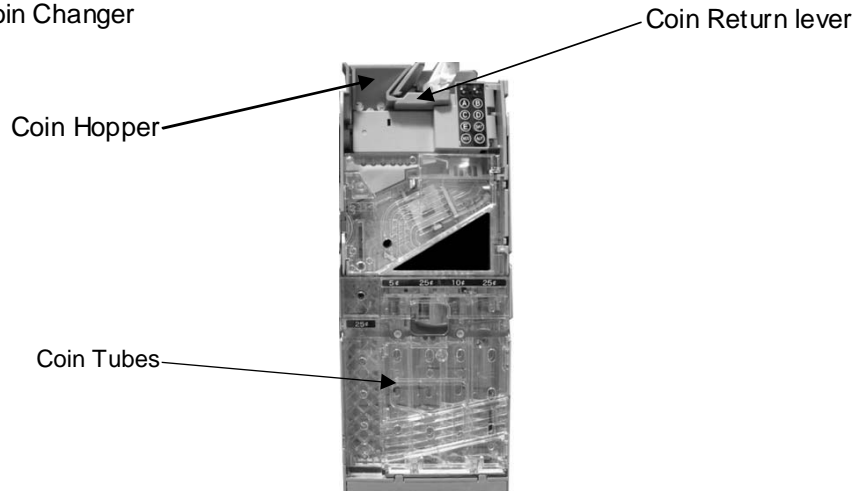

### **CLEARING COIN JAMS**

To clear a jam, remove the hopper assembly

1. To remove Hopper Assembly
  - a. Unlock and open the front door of Vendor. Unplug the Vendor
  - b. Remove the coin box, and pull the vertical shelf out.
  - c. Loosen the mounting screws that hold the Coin Return arm and Coin Chute to the vertical shelf, and shift this assembly up.
  - d. Push the thumb Tabs up, and tilt the Coin Hopper forward
  - e. Lift and remove. Note: The coin hopper is still connected to the Coin Changer by the ribbon harness that can be pulled free.
  - f. Clear Jam and reassemble.

### **CLEANING COIN CHANGER**

Your Coin Changer needs to be cleaned only when the Coin Changer will no longer read coins.

1. Cleaning the Optics. You will need cotton swabs [Q-tips], and a 50/50 water/isopropyl [rubbing] alcohol solution.
  - a. Unlock and open the front door
  - b. Remove the Coin Box, and Pull the Vertical shelf out.
  - c. Tilt The Coin Hopper open, there are two (2) Lenses on the flap and two (2) Lenses inside the coin hopper
  - d. Swab the lenses with the solution, and reassemble.

### **REMOVAL OF COIN CHANGER**

To Remove the Coin Changer.

- a. Remove the Coin Hopper as Above
- b. Disconnect Wiring harness
- c. Lift Coin Changer and remove.

### **BILL VALIDATOR**

The Bill Validator allows your customers to pay for their purchase with paper currency. Your Bill Validator is installed at the factory, and is set to validate \$1 and \$5 bills, but will not accept \$5 bills if the coin tubes are empty. The Bill validator verifies, accepts and stores paper currency but change is given in coins only.

### **BILL VALIDATOR CAPACITY**

The Bill Storage Box will hold approximately 250 bills.

## **BILL RETRIEVAL**

The bills your customers spend are kept in the Bill Storage Box.

1. To Retrieve Bills.
  - a. Unlock and open the Front Door.
  - b. Pull the Vertical Shelf out.
  - c. Open door located on top of bill collection box.
  - d. Close top door on bill collection box after bills are retrieved.

Figure 21 – Bill Storage Box

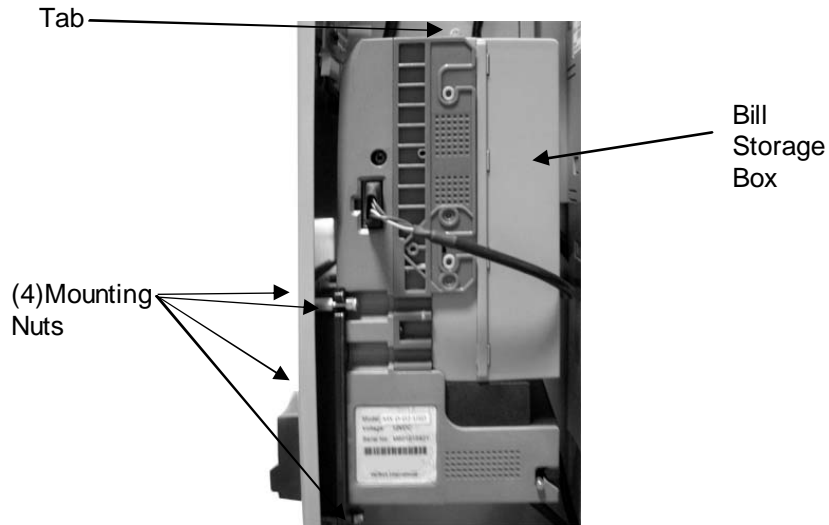

## **REMOVING BILL VALIDATOR**

From time to time it may be necessary to remove the Bill Validator for cleaning and clearing jams.

1. To remove the Bill Validator.
  - a. Unlock and open the Front Door, unplug vendor.
  - b. Pull the Vertical Shelf out.
  - c. Pull Tab forward and lift Bill Storage Box.
  - d. Disconnect Bill Validator from Wiring Harness.
  - e. Remove the Four (4) Mounting Nuts. (Fig. 21)
  - f. Remove Bill Validator

## **CLEARING BILL JAMS**

It is possible that a torn or damaged bill can jam within the Bill Validator, putting it out of service.

1. To Clear a Jam.
  - a. Remove Bill Validator as above.
  - b. Press Tab on bottom of Bill Validator, and pull Lower Housing free.
  - c. Remove Jam, and reassemble.

## **REFRIGERATION DECK**

Your Beverage unit incorporates a high efficiency refrigeration system having two air circulation fans to chill the cans and bottles. The refrigeration unit can be easily accessed by opening the Beverage unit door and sliding the front panel up and out. Remove the retainer fastener at the mid-point of the refrigeration deck and unplug the three wire harnesses (Fig. 22). The refrigeration deck can now be pulled out from the vendor. Please make sure you unplug wire harnesses prior to pulling all the way out.

The refrigeration deck is a pullout modular system consisting of Compressor, Condenser, Condenser fan, Evaporator, Evaporator Fan, Accumulator or Dryer, and Temperature Sensor which

communicates to the VMC. The temperature is pre-set at the factory for efficient and effective operation.

Figure 22 – Refrigeration unit

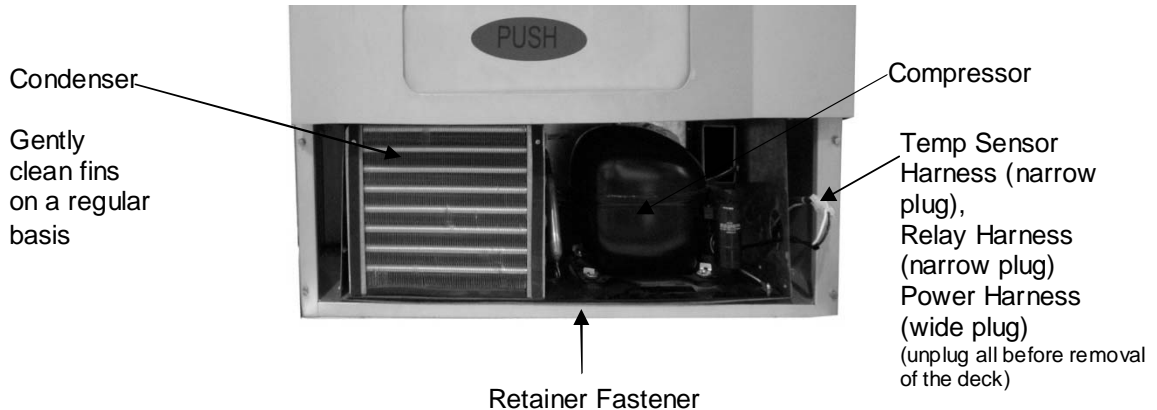

### **CLEANING THE CONDENSER**

Dust and dirt restricts good airflow and cooling of the condenser, due to which the refrigeration unit will not chill the beverages properly. Remove the front bottom panel of the refrigeration unit. Brush the dirt and dust from the condenser fins. You can also blow canned air, available at computer and office supply stores, on the condenser or vacuum clean it. Do not damage the fins of the condenser while cleaning. Reassemble the front bottom panel after cleaning.

### **REFRIGERATION**

Refrigeration is the transfer of heat from one area to another. In the case of this machine we are transferring the heat from the area containing the beverage selections to the outside of the machine and dissipating the heat throughout the room. The more heat we are able to transfer away from the beverages the colder they become.

This process is accomplished by the use of a sealed compressing system using an ozone friendly gas commonly known as R134a refrigerant. The system is comprised of several key mechanical components: the condenser, the evaporator and the compressor. The condenser is located in the lower front left of the machine and it is where the heat is dissipated from the cooling process and blown to the outside of the machine. The evaporator is located inside the machine towards the back of the cooling system underneath the beverage unit section being cooled. Its purpose is to absorb the heat from the drink selections and provide the cool air needed to refrigerate the beverages. The compressor is the heart of the cooling system and its purpose is to provide pressure and circulation of the refrigeration gas.

The refrigeration system is monitored and controlled by several key electrical components. The condenser fan, evaporator fan, temperature sensor, VMC, and the start and overload components located on the side of the compressor. The line voltage from the 115 volt AC outlet in the room is fed to the two fans, the condenser and the evaporator fans, and they run continuously as long as the machine is plugged into 115 volt AC power coming from the wall. The temperature sensor and VMC control the on and off cycling of the compressor. The temperature sensor is located on the back side of the refrigeration deck.

To determine if the compressor system is running it is sometimes difficult due to the fact that the compressor tends to be very quiet. The sound and slight vibration from the fans running can sometimes be mistaken for the compressor running. One way to tell if the compressor system is running is to cautiously place your hand on the compressor to feel if it is warm. **CAUTION** as it may be hot to the touch. If the compressor is stone cold and stays that way for an extended period of time, you can assume there is an electrical problem in the circuitry or components that operate the compressor. Another way to see if the compressor is running is to feel the air exiting the condenser coils from the front to see if there is any heat.

Any problems with the fans running can also lead to a cooling system failure. In order for any cooling system to operate properly it is most important that all fans are running and that the condenser coil is kept clean and free of any dust, dirt or obstructions.

## **COMMON QUESTIONS AND ANSWERS**

### Product prices, payment systems and currency:

#### **Q. How high can I set my Prices?**

- A. Each selection can be priced individually up to \$99.95. Note: Keep in mind when setting a price that you may have an effect on the Exact Change Only message.

#### **Q. Why does my Exact Change light stay on?**

1. Insure that proper levels of coins are loaded into the changer.
2. Check prices to insure all prices are correct. If there is a price set at \$99.95 this will cause the light to stay on.
3. Insure that the changer is properly connected.

#### **Q. Why do the coins I insert reject immediately?**

1. Insure that the changer harness is connected properly. **Note: always disconnect power to snack vendor before disconnecting and reconnecting payment system harnesses.**
2. Insure there is no pressure on the coin return lever located on the changer itself. Slight pressure will cause the changer to automatically reject coins.
3. Clean changer (refer to manual page 23 for cleaning instructions).
4. Verify in PD that the coin changer is enabled.

#### **Q. Why won't the unit take more than 3 - \$1 bills, or more than 1 - \$5 bill?**

- A. The VMC protects the amount of change in the changer and will only allow the bill acceptor to take bills up to the highest vend price in the machine. For example, if your highest vend price is \$3, after inserting 3 - \$1 bills or 1 - \$5 you will not be able to insert more bills.

#### **Q. Can customers reach down and help themselves to product?**

- A. No, they can't. The product door is a Triangle shaped flap designed to deter reach and theft. When pushed, the back of the triangle flap will come in contact with the bottom product tray and will become an anti-theft wall to act as a block.

#### **Q. In the event of a power outage, will I have to reprogram my prices, settings, etc.?**

- A. No, your settings are stored, but take note that you may have to reload your changer if the Exact Change Only light is on.

#### **Q. Are the price decals installed at the factory? Are there extras and where do I find them?**

- A. No, the price decals are not installed at the factory. Follow the Plan-o-Gram that comes with the machine to set the prices correctly and install the proper decals. The denominations included with the machine are as per the Plan-o-Gram. The prices range from \$0.75 to \$2.00 and 42 extra price points are included to allow some modifications.

#### **Q. Are the prices preprogrammed at the factory? Is there a default setting for all of the programming functions?**

- A. Yes, the prices are pre-programmed at the factory. However, programming the price settings is a great way to get familiar with your machine while you are in test mode and prior to locating the machine. Your first-hand knowledge will allow you a greater understanding of how the equipment works.

#### **Q. How often should I clean my payment systems?**

- A. This will depend on how much traffic you have at your machine – the more money inserted, the dirtier the payment systems will become. Clean your payment systems on a monthly basis to begin with. Lengthening the time between cleanings is at your own discretion.

**Q. What is the proper way to load my changer?**

- A. In order for your VMC to keep an accurate coin inventory, enter into service mode, scroll through to “tE”, and load coins in through the front coin slot, as if you were inserting money to purchase items. Once the coins start dropping into the coin box, that means that the coin tubes are full and the VMC has an inventory of coins stored and will calculate transactions accordingly.

Beverage unit temperature and refrigeration:

**Q. What type of environment is the equipment designed for?**

- A. The Office Deli is specifically designed for indoor use only. Optimal location temperature is 75° F, with 40% RH. Avoid placing unit in direct sunlight.

**Q. How do I clean my condenser?**

- A. Remove the front bottom panel of the refrigeration unit. Brush the dirt and dust from the condenser fins. You can also blow canned air (available at office supply/computer stores) on the condenser or vacuum clean it. Do not damage the fins of the condenser while cleaning. Reassemble the front bottom panel after cleaning.

**Q. How do I set my temperatures, and what is the factory recommended low and high settings?**

- A. The temperature setting is factory set to industry standard 37° F for the lower limit, and 42° F for the upper limit. Refer to Page 20 of this manual for instructions on how to alter temperature settings.

**Q. How do I check the temperature on my unit (version 25 or higher)?**

- A. Press the 10 key to display the current temperature for 20 seconds on the LCD screen.

**Q. My beverage selections are not cold enough. How do I get them colder?**

1. Check temperature setting by going into tS function, and refer to the steps in this manual on page 20.
2. Clean condenser coil (see Refrigeration section of this manual). The coil should be clean and lint free, if dirt or lint build-up is on coil, this will restrict air flow and cause the compressor temperature to rise above operating temperatures and compromise cooling.
3. Insure condenser fan and evaporator fans are running.
4. Check refrigeration harness and insure proper connection. **Note: this should be done with power cord unplugged from wall outlet for personal safety.**
5. Insure you beverage vendor is placed in a location that it is designed for, which is indoors only. Outside or non climate controlled environments will compromise cooling.

If further assistance is needed, please contact Seaga Customer Care or a local refrigeration technician.

**Q. My beverages are not cooling at all.**

1. Insure through the tS function that the refrigeration deck is turned on. Refer to the steps in this manual on Page 20.
2. Insure the unit has power – test wall outlet where the unit is plugged in.
3. Check that refrigeration connections are properly connected.

**Q. Why does my display switch from “ErrE” to “00.00”? Why are my beverages warm?**

1. This is caused by the temperature sensor not communicating.
2. Check to make sure the refrigeration harness is correctly connected to AUX connection on the VMC.
3. Insure temperature sensor harness is properly connected on refrigeration deck.
4. Once proper connection is made, error will disappear from display. Go into errors and clear hard error recorded.

Product vending:

**Q. Why won't my snack/entrée selection vend?**

1. Check to insure proper connection is made to vend motor.
2. Go into tE, and choose selection, this will home the motor if it is out of home.
3. Inspect harness for visual breaks and replace harness if broken wires are found.
4. If above steps fail, switch motor with known working motor, perform a tE1 test to recapture motor, then perform an individual motor test to insure that the motor is working properly.

**Q. Why are vertical columns in my beverage unit double vending?**

1. Check bottle diameter to insure the bottle is not too small to vend (should be with 2 ¼" to 3" in diameter).
2. Insure shim is properly installed.
3. Run lane in tE mode and look to see if any error is displayed after vend is made. If error is displayed check wiring to home switch located behind motor.
4. Check home switch itself for cracks or breaks, replace if necessary.

**Q. I've loaded my beverage product chutes and columns to capacity – why does my display say Sold Out?**

1. In the can drink chutes, make sure the cans are loaded correctly and firmly pressed against the teeter totter mechanism to fully depress sold out switch.
2. In can drink columns, insure wiring to sold out switch is connected properly.
3. In can drink columns, remove teeter-totter mechanism and inspect sold out switch to insure that the lever is not bent. You may be able to slightly bend this back in place if necessary.
4. Run lane in tE mode to insure motor is being recognized. If the VMC loses recognition to a motor, it defaults to reading sold out. Perform a tE1 test to recapture the motor to the VMC.
5. In the vertical column, insure product is fully depressing the sold out lever.
6. In the vertical column, insure switch lever is resting properly against sold out flap in the lane.
7. Insure wiring is properly connected to sold out switch.

If both vertical, and can drink lanes are all reading sold out, inspect main beverage harness for a break in orange wire.

**Q. A product keeps hanging up or getting stuck. What can I do?**

1. The product may be loaded incorrectly in the helix coil or the product may be in the wrong size helix coil.
2. Product pushers may help bring the product forward as the helix coil turns and help the product drop at a more even level.

**Q. How do I install the Product Pushers?**

- A. Align the product pusher groove with helix coil diameter and slide along the helix coil with triangle pointing towards the front (away from the product). Slide until the product pusher is completely inside the helix coil with about ½" from the helix coil end point.

**Q. A selection will try to vend but the product will not come out. What do I need to do?**

- A. The most probable answer is that the helix coil has become detached from the driver. Remove the jammed item and then check to see if the helix coil is free from the driver. If so, snap the helix coil back into the driver and then home the motor.

Display and keypad:

**Q. Why isn't my display working?**

1. Insure the snack machine is plugged into a working outlet

2. Check the harness connection to the display board. Slide out the shelf that the display is mounted to, look at the bottom of the display board to locate the display harness, press upward on the connection to insure that it is connecting properly. It may take a few seconds to have the display come back on if connection was not made initially.
3. Check the connection on the VMC labeled display and insure that proper connection is made.

**Q. My Keypad is not working/ some selections not working**

1. Check harness connections to the keypad ribbon harness that is located behind the keypad on the slide-out shelf.
2. Inspect key pad for damage caused by selection pressed with foreign objects. Large dents, tears, scratches may damage the membrane and result in failure.
3. Check connection on VMC labeled keypad and insure that proper connection is made.

**Q. Everything is working properly on my unit so why are errors listed under Display Errors?**

- A. There are hard errors that simply need to be cleared. Go into the Clear Errors from the Menu and follow instructions to clear (See Page 18).

Transporting and installing:

**Q. Do I have to test my equipment before placing it on location? Must I disassemble to transport to the location? Is there a way to do a general check of equipment without full assembly?**

- A. We suggest full testing prior to the unit being moved to the location. Why? It gets you familiar with the machine so that you look professional and efficient when at the location setting up the machine. Complete assembly of the machine for testing is not required; you could test vend the snack machine on the floor next to the Beverage unit or set it on top of the Beverage unit. The Entrée unit could be tested sitting next to the snack machine as well.

**Q. Can the snack and beverage machine be transported while attached? Loaded?**

- A. The units should never be transported attached. Additionally, transporting with product loaded voids manufacturer's warranty and can damage your equipment. Transport units unattached and empty of product/change only.

**Q. Can I place the beverage unit on its side for transport?**

- A. Never place the beverage machine in any other position but upright. There are numerous components that can be jostled out of place, becoming very problematic for you. Once the machine is set in place, the compressor needs to rest for a minimum of 2 hours prior to running in order for the oils in the compressor to return to their non-threatening position.

**Q. Are the beverage shims pre-installed at the factory?**

- A. Yes, the shims are pre-installed; the far left vertical column is pre-set for milk products (D7) and the inner column (D6) is pre-set for bottled Beverage products.

**Q. Are there different helix coils that will hold a larger number of products (more product spaces)?**

- A. The helix coils installed are specific to the Plan-o-Gram. For other helix coil options, please call Seaga Customer Care.

**Q. My Beverage Unit door will not line up & lock. What can I do?**

- A. This may be caused by an unlevel machine, perhaps on an uneven surface. We suggest you put all the units together and securely bolt them together as per the instructions. This should resolve any fit issues.

**Q. Should I use a surge protector for the equipment?**

- A. A surge protector is a small investment that can protect your equipment. We recommend using a surge protector.

Figure 23 – Electrical Wiring Diagram

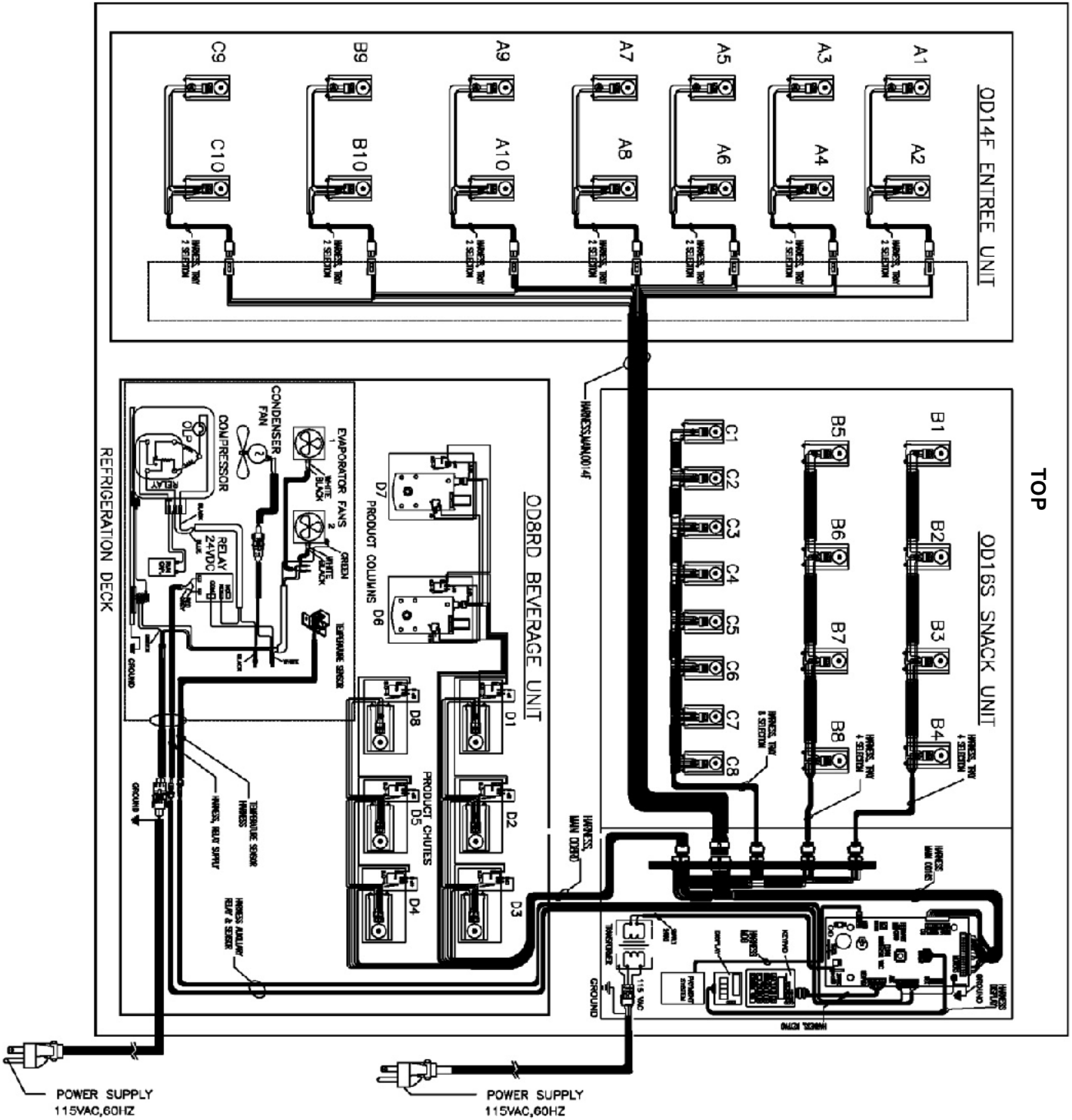
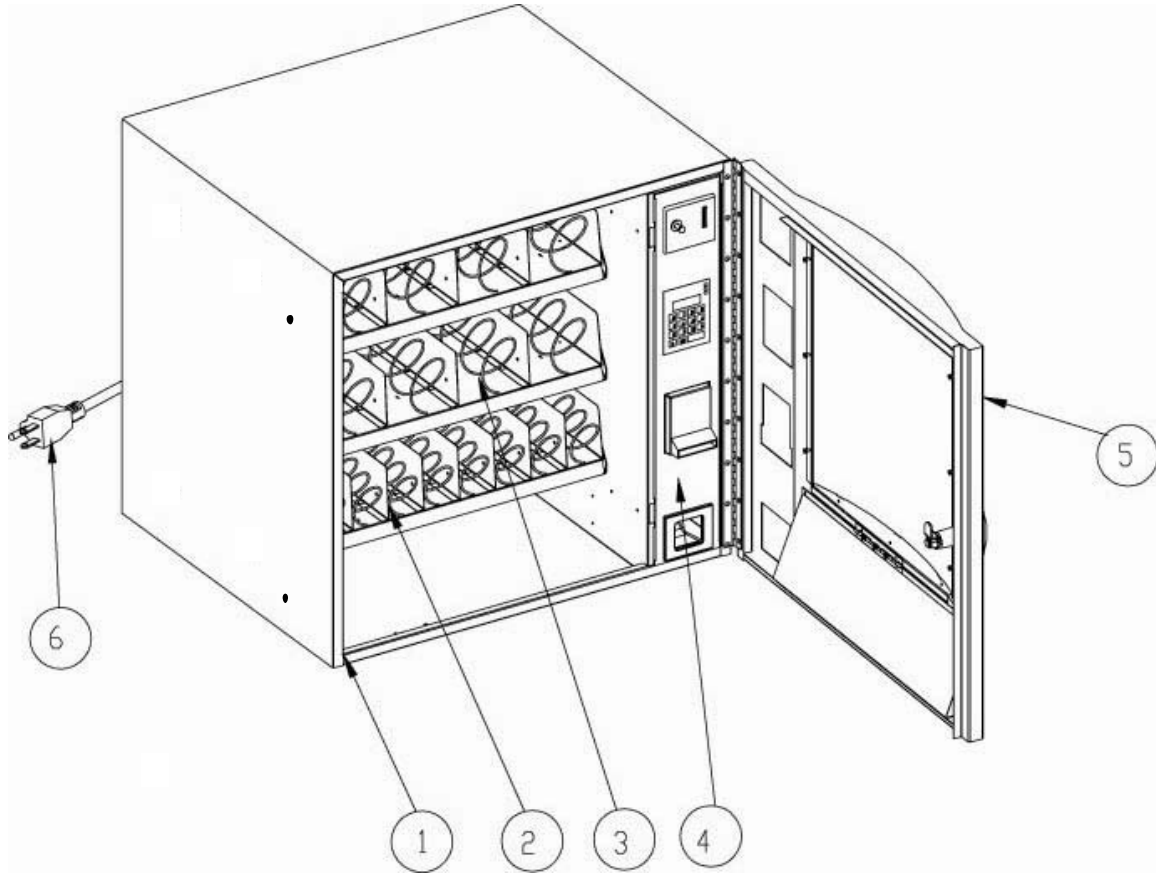
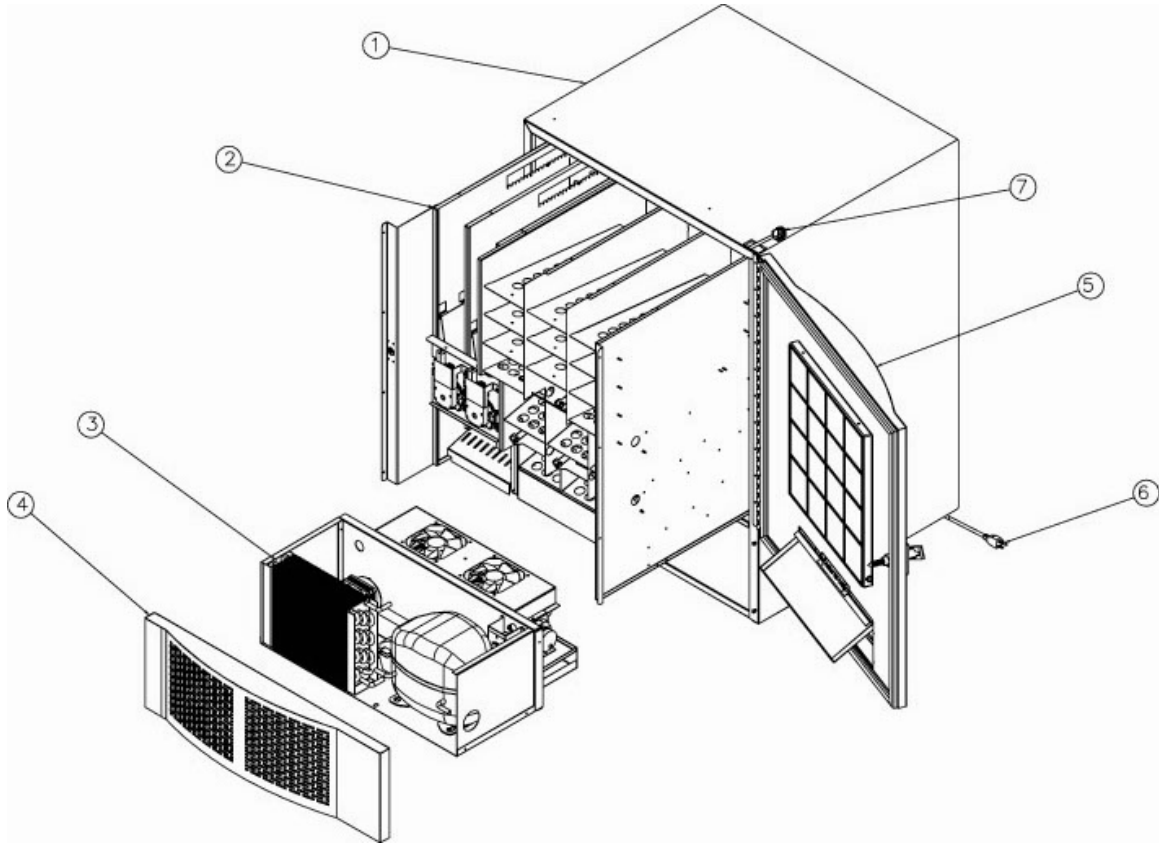

Figure 24 – Snack Unit (OD16S) Parts List



ITEM	PART NO.	DESCRIPTION
1	SA9209	MAIN CABINET
2	TAI818	8- SELECTION PRODUCT TRAY
3	TAI814	4-SELECTION PRODUCT TRAY
4	WE9225	SLIDE-OUT VERTICAL SHELF
5	SA9215	DOOR
6	ELI627	POWER CORD

Figure 25 – Beverage Unit (OD8RD) Parts List



ITEM	PART NO.	DESCRIPTION
1	SA9401	MAIN CABINET
2	SA9410	PRODUCT DELIVERY SYSTEM
3	REI801A	REFRGERATION DECK ASSEMBLY
4	WE9410	FRONT PANEL
5	SA9420	DOOR
6	ELI627	POWER CORD
7	ELI824D	MAIN HARNESS BEVERAGE UNIT

Figure 26 – Entrée Unit (OD14F) Parts List

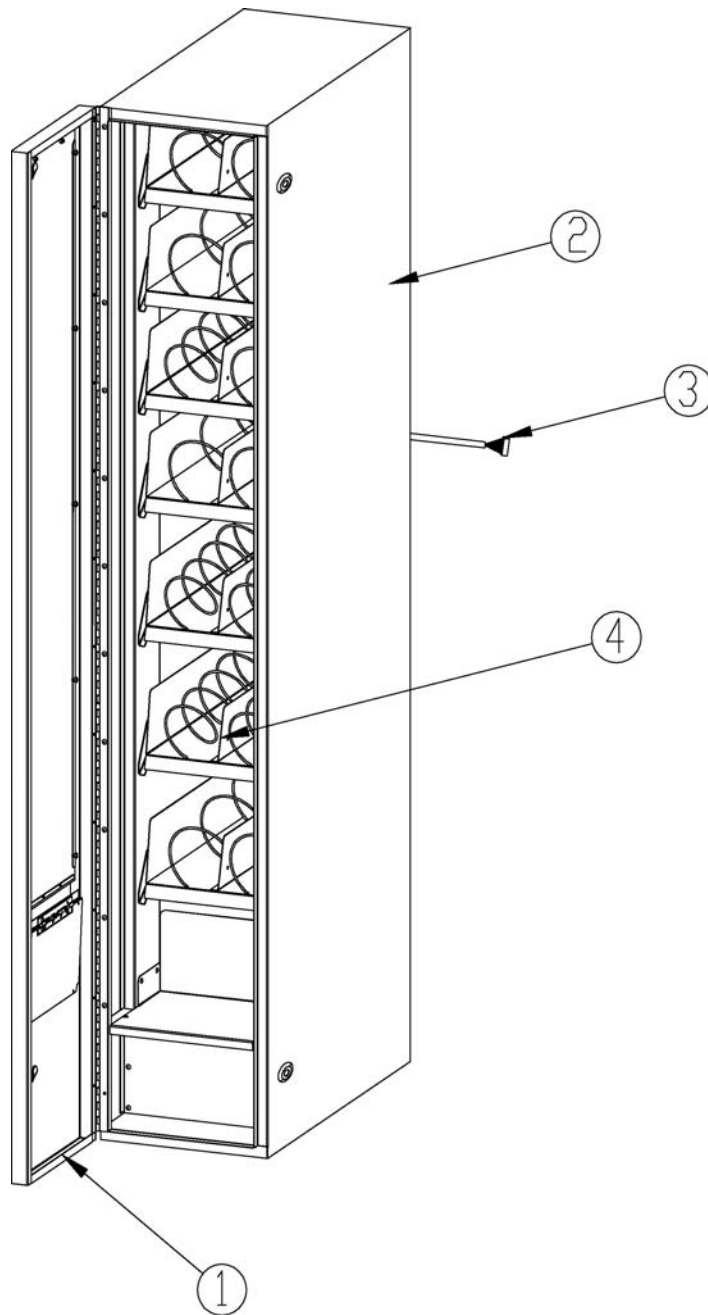

ITEM	PART NO.	DESCRIPTION
1	SA9310	DOOR
2	219301	MAIN CABINET
3	ELI823C	MAIN HARNESS ENTRÉE UNIT
4	TAI824	2-SELECTION PRODUCT TRAY

This page intentionally left blank for your notes:

## APPENDIX A

### NAMA KIT INSTALLATION

The following instructions will assist you in installing the NAMA Kit included with your parts pack. The NAMA Kit installation will insure compliance with guidelines and regulations set in place by the National Automatic Merchandising Association and assure your location of your professional quality vending service.

Your NAMA Kit should be installed on location using the following guidelines:

Figure 1 – NAMA Kit Items

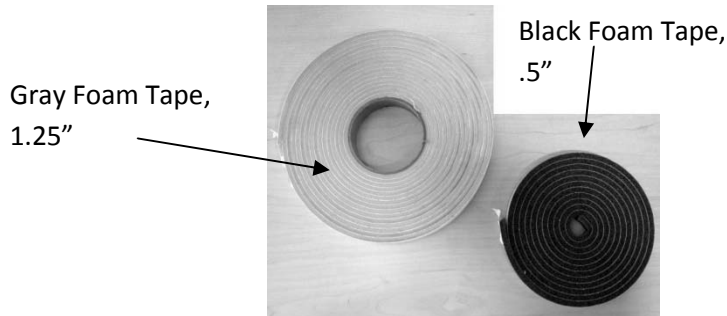

Unpack your NAMA Kit on location and verify that the items shown above are included. Move the Entrée Unit into position with the side exposed. Apply Black Foam Tape around both vertical sides and the top of the Entrée Unit as shown (Figure 2).

Figure 2 – Black Foam Tape

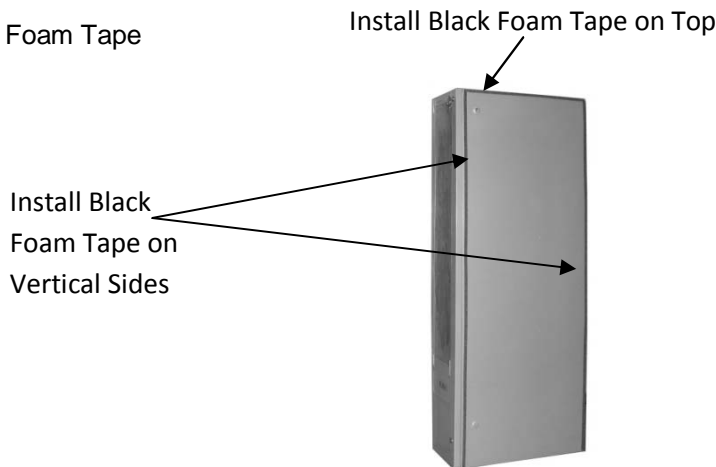

With Black Foam Tape installed as shown, move Entrée Units into position and fasten as instructed in this manual. After you have completed installation and placement of the OD38, (minimum 6" from wall) you can now install the Gray Foam Tape.

Remove front grill from Beverage Unit by opening the beverage door and lifting up the grill while pulling away from machine. Open the Entrée Unit door. Install Gray Foam Tape completely around the bottom of the entire machine while in position on location. Be sure that the tape seals against the vending machines and the floor to prevent dust from getting under your equipment. There is enough tape to fully cover the entire circumference of the machines. See Figure 3:

Figure 3 – Gray Foam Tape

Install Gray Foam Tape around all sides of complete machine on location.



Install Gray Foam Tape around all sides of complete machine on location.

