

MANUFACTURER'S WARRANTY

WHAT IS COVERED:

Manufacturer warrants TO THE ORIGINAL PURCHASER ONLY that each item of equipment manufactured is free from defects in material and workmanship under normal use and service. Manufacturer's obligation under this warranty shall be limited to repair or replacement, at our plant, of any parts of the equipment which shall, within one year of the date of shipment to the original purchaser, be demonstrated to be defective. The original purchaser may obtain repair or replacement of the equipment under this warranty by returning the defective item or entire vendor to the Manufacturer, freight prepaid.

WHAT IS NOT COVERED:

Manufacturer's warranty obligations DO NOT EXTEND TO OR INCLUDE installation expenses, vandalism, or difficulties resulting from failure to operate equipment in accordance with Manufacturer's instructions under competent supervision and difficulties due to changes in vended products which are beyond the control of Manufacturer.

SPECIAL NOTE: Manufacturer is not responsible for any loss of income due to a vending machine being out of service due to a warrantable item.

This warranty is in lieu of all other warranties, expressed or implied, including the warranty of merchantability and fitness or use, and of all other obligations or liabilities on Manufacturer's part. Manufacturer neither assumes, nor authorizes any other person to assume for it, any other liability in connection with the sale of equipment manufactured by itself. This warranty shall not apply to equipment manufactured or any part thereof which is subject to accident, negligence, alteration, abuse, misuse or damage in shipment. The term "original purchaser," as used in this warranty, shall be deemed to mean that person for whom the equipment is originally installed.

Manufacturer is not liable for any incidental, consequential or other damages of any kind whatsoever, directly or indirectly, arising from the use of the equipment whether based upon theories of contract negligence or tort.

Effective 9/01



BV155

Beverage Vendor



Operator's Manual

INTRODUCTION

Congratulations on the purchase of your new vending machine. This machine has been designed to give you many years of dependable service. It requires little maintenance and is easy to set up and operate.

READ THIS MANUAL COMPLETELY

Your machine is designed to operate simply and reliably, but to take full advantage of your vendor, please read this owner's manual thoroughly. It contains important information regarding installation and operations, as well as a brief troubleshooting guide.

EQUIPMENT INSPECTION

After you have received your equipment and have it out of the box, place it on a secure surface for further inspection. **Note:** Any damages that may have occurred during shipping must be reported to the delivery carrier immediately. Reporting damages and the seeking of restitution is the responsibility of the equipment owner. The factory is willing to assist you in this process in any way possible. Feel free to contact our Customer Care Department with any questions you may have on this process. It is important that you keep the original packaging for your vending machine at least through the warranty period. If your machine needs to be returned for repair, you may have to purchase this packaging if it is not retained.

Once you have your vendor located, we suggest that you keep this manual for future reference, or you can view this manual online at seagamfg.com. Should any problems occur, refer to the section entitled "COMMON QUESTIONS AND ANSWERS". It is designed to help you quickly identify a problem and correct it.

For Technical Support & Service Contact our Customer Care Dept.

8:30 a.m. - 4:00 p.m. CST. Mon thru Fri
815.297.9500 ext 160
815.297.1700 Fax
email: customercare@seagamfg.com

For Parts

Contact our Parts Dept.

8:30 a.m. - 4:00 p.m. CST. Mon thru Fri
815.297.9500 ext 160
815.297.1700 Fax
email: parts@seagamfg.com



700 Seaga Drive
Freeport, IL 61032 U.S.A.
Online: seagamfg.com

Figure 16 Optional \$.80 configuration

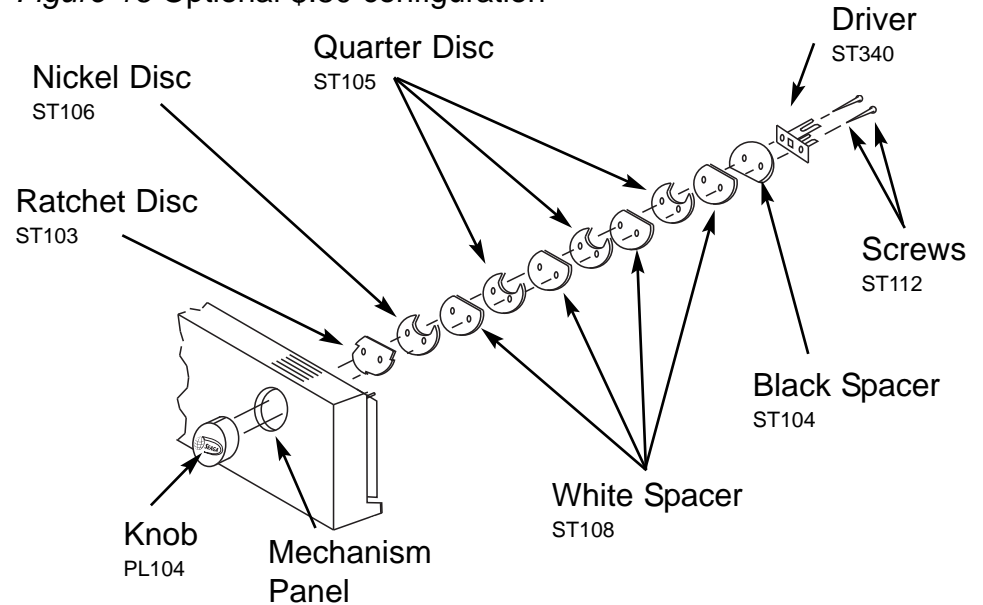

Figure 17 Optional \$1.00 configuration

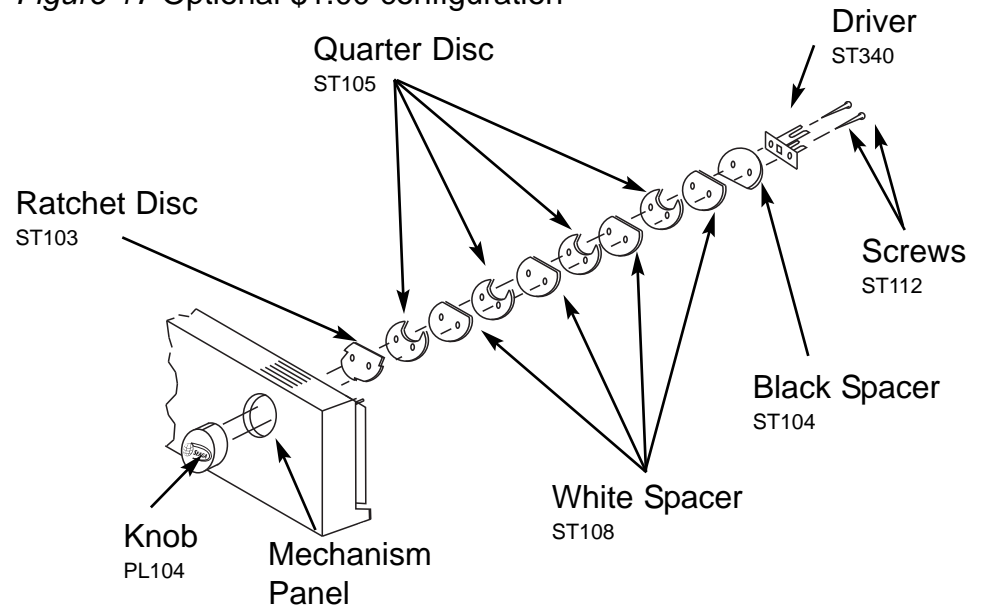

Figure 14 Optional \$.70 configuration

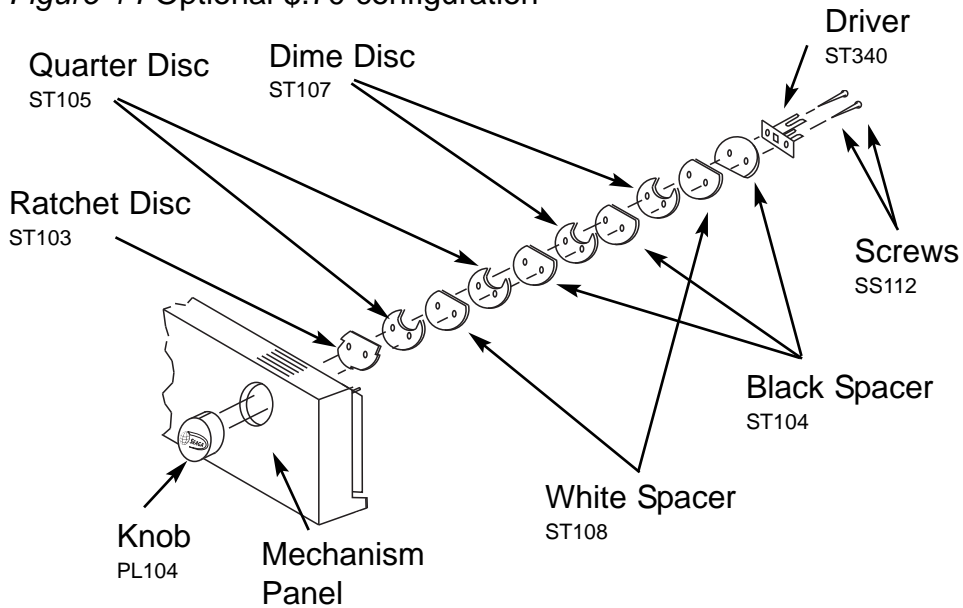
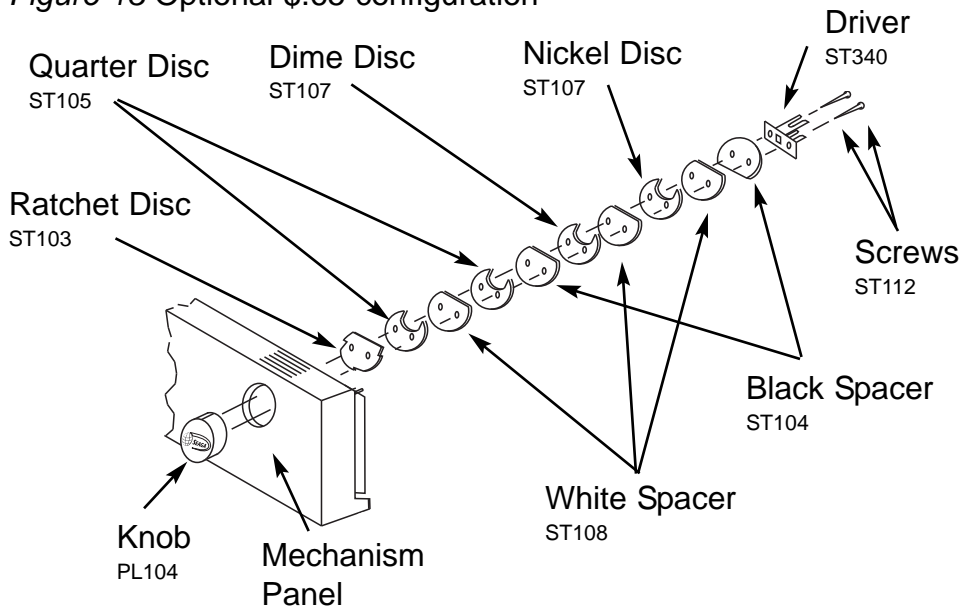
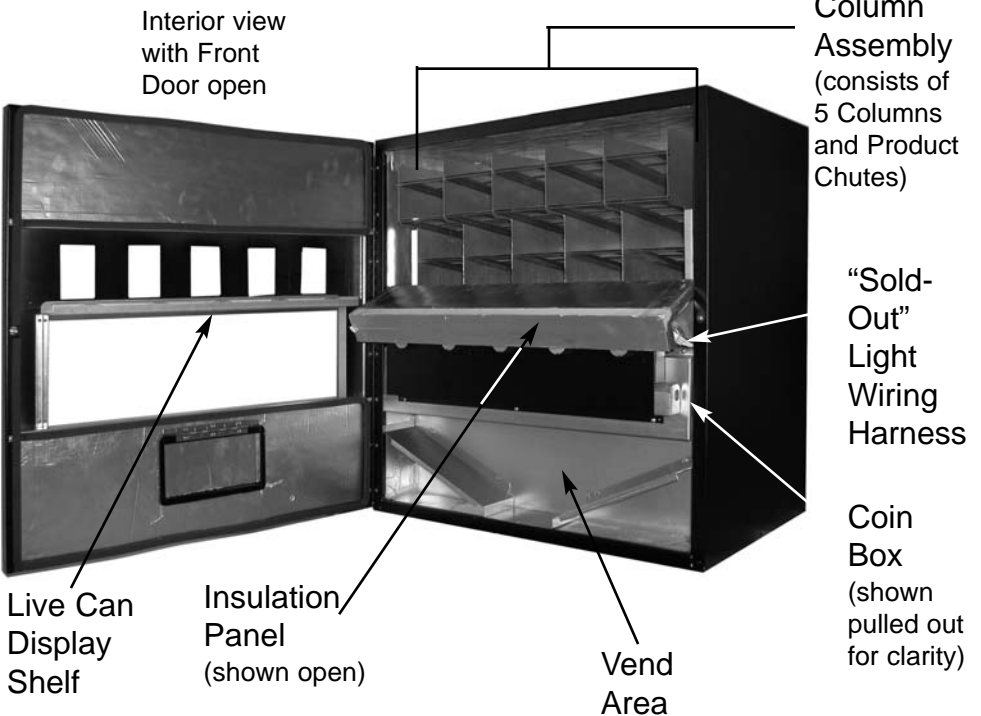
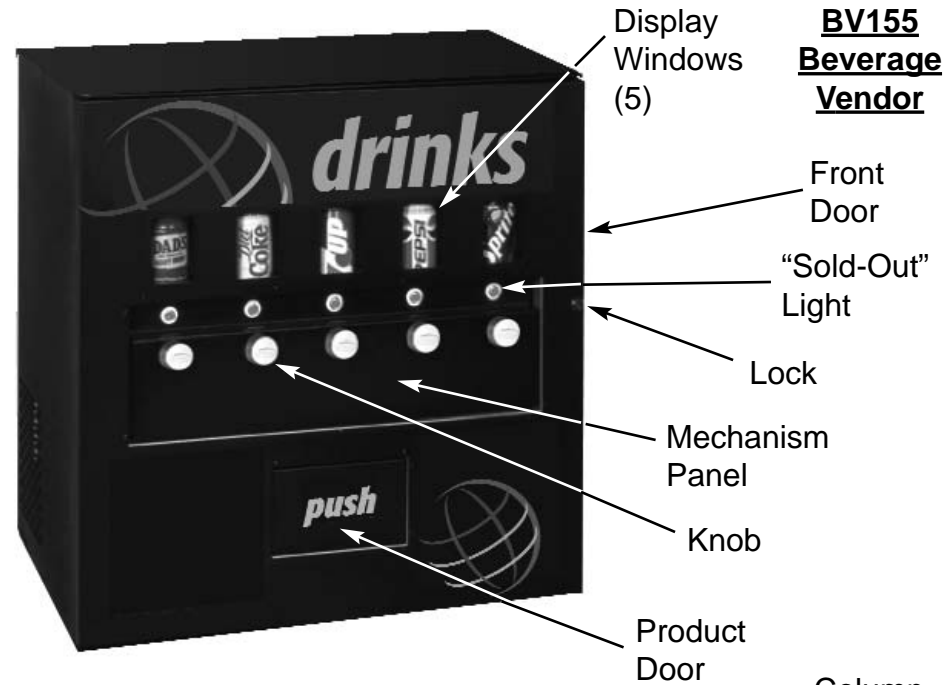

Figure 13 Optional \$.65 configuration



**BV155
Beverage
Vendor**



LOCK

Your BV155 has one (1) screw type Lock on the Front Door. To unlock the Front Door, insert key and unscrew counter-clockwise. When unlocked the Front Door swings open. To lock, push Front Door closed and turn Lock clockwise until the Gasket is firmly engaged. **Note:** Do not over tighten, as you could damage the Lock and Gasket.

ELECTRICAL CONNECTION

The BV155 requires one (1) 120 VAC grounded outlet.
BV155 120 Volts 4 Amps

TEMPERATURE CHECK

Once your vendor is unboxed you will need to plug in your vendor and allow it to come to operating temperature. We recommend that you perform this check prior to placing your vendor on site. It will take about 24 hours for the vendor to reach operating temperature of 38°- 45°. Temperature fluctuation is normal, and will depend upon your facilities climate. The Thermostat is located in the back of the vendor. **Note:** Never lay your vendor on its side.

To adjust the temperature, turn the Adjustment Slot (1/8" at a time) clockwise to a colder setting. (Fig. 1) **Caution:** Do not turn the Adjustment Slot to 10 as the Compressor may freeze, and void your warranty. The factory setting should cool your vendor properly, any adjustments beyond the factory setting should be done with caution.

MOUNTING

Your BV155 is intended as a stand alone vendor or can be mounted to the optional BX5 Stand. Also the BV155 can be mounted to the CS9, CS10, CS18, CS20, to form a Compact Mechanical

Figure 1 Thermostat

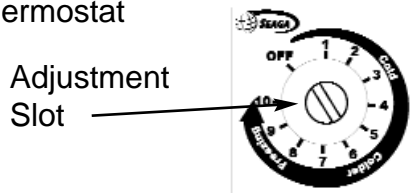

completely counter-clockwise. Watch the fan at the rear of the Compressor, it should stop turning, and the Compressor should shut off. Open or leave the Front Door ajar overnight to thaw the evaporator coil. On the next day turn your Thermostat to 3 and check for proper cooling.

Figure 11 Optional \$.50 configuration

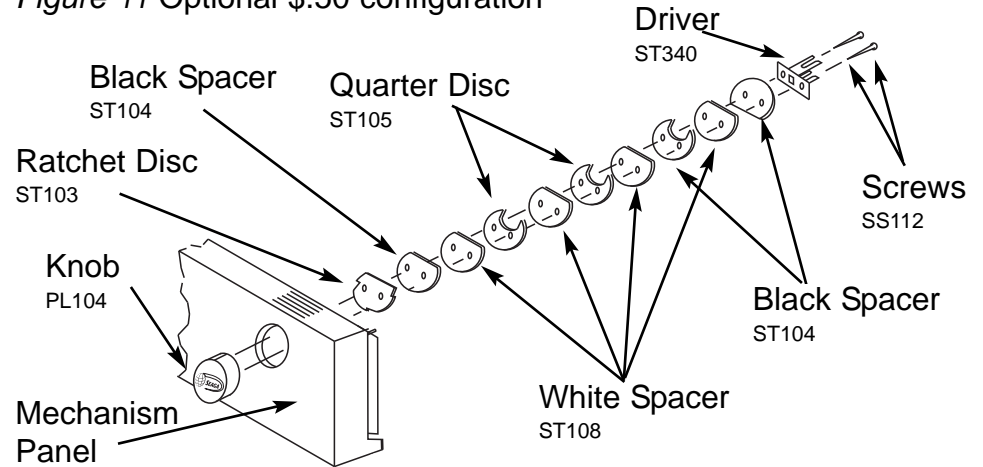
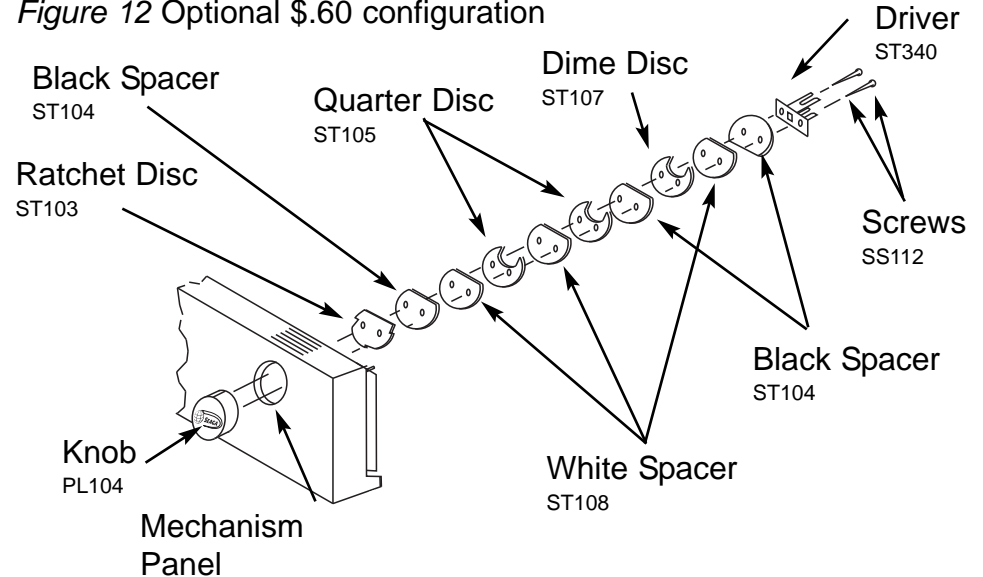

Figure 12 Optional \$.60 configuration



REFRIGERATION SYSTEM

Q: The Compressor is running, but the vendor is too warm.
A: Turn the Adjustment Slot (1/8" at a time) clockwise to adjust to a colder temperature.

Make sure that the air flow is not restricted, there should be 6" clearance on left and rear sides.

The Compressor may be frozen. Turn the Thermostat completely counter-clockwise. Watch the fan at the rear of the Compressor, it should stop turning, and the Compressor should shut off. Open or leave the Front Door ajar overnight to thaw the evaporator coil. On the next day turn your Thermostat to 3 and check for proper cooling.

Thermostat may not be working properly.

Check for an air leak in the door seal.

Compressor may be undercharged with R134A.

Q: Why doesn't the Compressor cycle, why is my Compressor making noise but the cans are not getting cold?

A: Thermostat may not be working properly.

The vendor may have been unplugged, and plugged back in too quickly. Unplug vendor for 12 hours and plug back in.

The Compressor may be frozen. Turn the Thermostat completely counter-clockwise. Watch the fan at the rear of the Compressor, it should stop turning, and the Compressor should shut off. Open or leave the Front Door ajar overnight to thaw the evaporator coil. On the next day turn your Thermostat to 3 and check for proper cooling.

Compressor may be defective.

Q: Why is my Evaporator freezing?

A: Check and make sure the Air Circulation Fan is working. The Thermostat may be stuck open. In this case turn the Thermostat completely counter-clockwise. Watch the fan at the rear of the Compressor, it should stop turning, and the Compressor should shut off. If it does not, then the thermostat needs to be replaced.

Q: My cans were really cold, and now my unit is not cooling.

A: The Compressor may be frozen. Turn the Thermostat

Combination Vendor. The mounting instructions to form Combination Vendors are featured in the Operator's Manuals for all of the models of snack vendors.

Mounting to the BX5 requires no hardware, and the BX5 ships fully assembled.

1. To Mount to the optional BX5 Stand.

A.) The BV155 sits atop the BX5 stand and is held in place by the rear and side flanges. (Fig. 2)

Note: The BV155 rests atop the BX5 stand, attaching the Stand permanently to the BV155 is at the owner's discretion.

Figure 2 Optional Stand Mounting

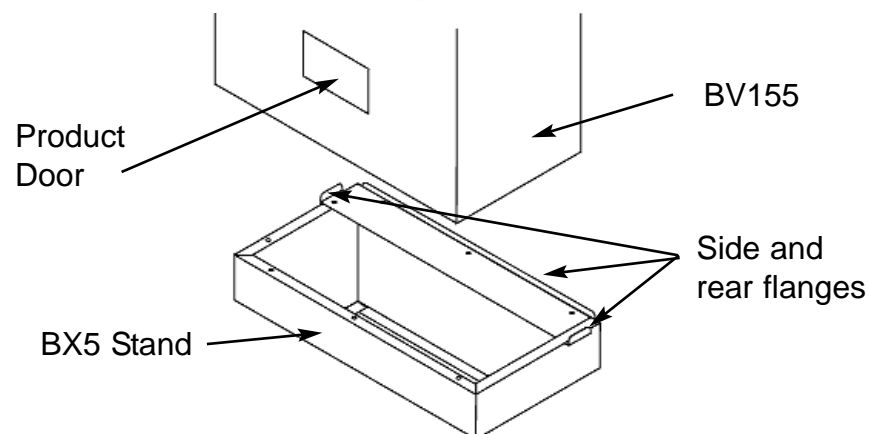

DELIVERY SYSTEM

The BV155's Delivery System (Fig. 3) consists of the Mechanism Panel, Driver Mechanisms, the Product Chutes, and the Can Spiral Coils. The Mechanism Panel is the front panel. This panel controls the receiving of money and the action of the Can Spiral Coil. Once the correct amount of money is received, the Mechanism Knob can be turned clockwise to the right. Product is vended by turning the Mechanism Knob one (1) complete revolution. There is a sold out switch near the end of each Product Chute that will turn on the selections "Sold-Out" Light when it does not detect product.

Note: When the "Sold-Out" Light is lit, there will be no cans of product remaining in the Product Chute.

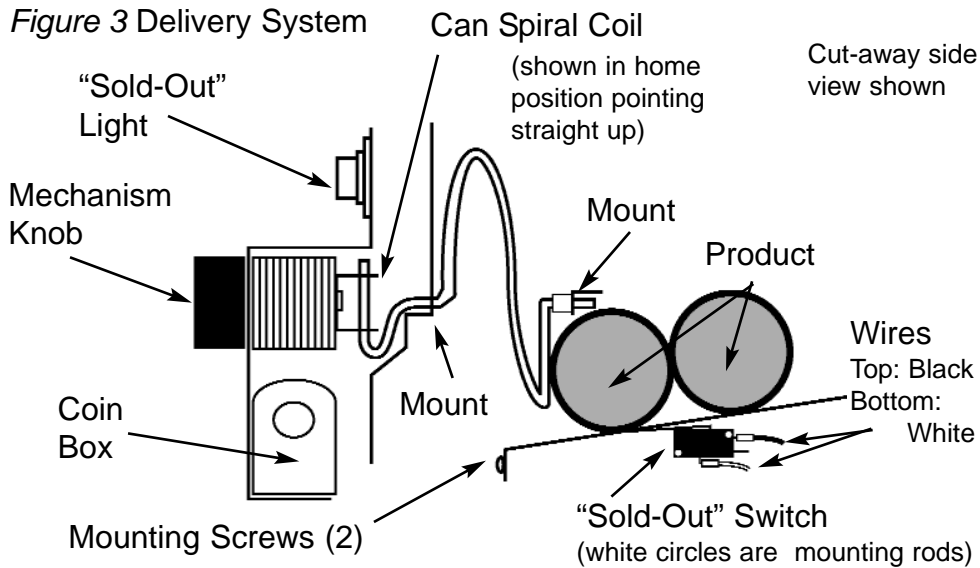

The Driver Mechanism (Fig. 4) comes preset at \$.75 but can be changed to suit your needs. The Coin Sub-Assembly is made up of a series of discs consisting of white, black and metal Coin Discs. The white spacers are thinner than the black, and the combination of the two place the Coin Discs in the proper position to receive coins. Contact our Customer Care Dept. for additional instructions on changing your Coin Sub-Assembly if necessary.

Figure 4 Driver Mechanism reference

All discs are the “Coin Sub-Assembly”

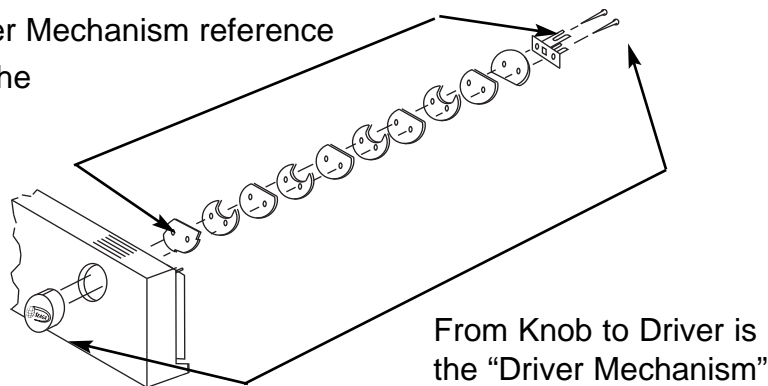

correct key is being used, your Lock may have been damaged or vandalized. Vandalism to locks is quite common. Having spare Locks in your toolbox at all times is recommended.

- Q: How do I remove a Lock that won't open.
A: Drill into the center of the Lock with a 1/4" drill bit. The Lock should fall apart and be easily removed. Increase the bit size and try again if the Lock does not come out.
- Q: What can I use to clean the outside of my vendor?
A: A lint free rag and a mild window cleaner are recommended. Be sure however not to directly spray decals as the ink could run.
- Q: Cans occasionally stick in my Delivery System.
A: This is not uncommon. Some cans may have defects or foreign matter that may cause them to hesitate, resulting in delayed advancement of product. The vendor may not be level.
- Q: How does my BV155 know it's out of product?
A: There is a sold out switch near the front of each Column that the cans roll over, that will turn on the "Sold-Out" Light when it does not detect product. **Note:** When the "Sold-Out" Light is lit, there will be no cans of product remaining in the Column.
- Q: The “Sold-Out” Light is off, but there is no product in the Column.
A: Check “Sold-Out” Light wiring harness connection. Check “Sold-Out” Switch wiring connection. “Sold-Out” Light may be burned out. “Sold-Out” switch may be defective.
- Q: The “Sold-Out” Light is on, but there is product in the Column.
A: Product may be jammed in the Column. “Sold-Out” Switch may be stuck. Check “Sold-Out” Light wiring harness connection. Check “Sold-Out” Switch wiring connection. “Sold-Out” switch may be defective.

the Driver Mechanism section (Pgs. 5 & 6) of this manual for proper placement of the Coin Rejecter.
(See Fig. 7 & Fig. 11)

Q: My mechanism screws keep coming loose.
A: Remove Mechanism Panel. Disassemble Knob. Apply lock tight to Knob screw threads. If this does not remedy the problem a replacement Knob may be needed.

Q: My mechanism rotates backward.
A: Your Knob should not do this. Remove the Mechanism Panel and check for proper placement and condition of the Anti-Reverse Dog.

Q: My mechanism rotates but product will not drop.
A: Check to see if the product is jammed in the Column. Check to see if the vendor is level. Check product for damage, and make sure it is the proper size.

Q: My knob turns ¼" turn and jams.
A: First remove your Mechanism Panel. Check the position of the coins to see if they are in-between the Coin Rejecter fingers. If this is the case, place a screwdriver in-between the Coin Rejecter and the coins and lift up freeing the Coin Rejecter. At this point the Driver Mechanism can now be rotated backwards. Reposition the Coin Rejecter fingers with your screwdriver to line up with coins and vend through. (Fig.8)

Q: Why does my product double vend?
A: The Can Spiral Coil may not be centered in the slots on the Driver. (Fig. 8)
The Anti-Reverse Dog is not engaging properly.

GENERAL

Q: Can customers reach up and help themselves to product?
A: No. The Vendor is designed to deter reach-up theft.

Q: My key won't turn my Lock to open.
A: Check to be sure that you are using the proper key. If the

1.To access Coin Mechanism:

- A.) Unlock and open Front Door.
- B.) Locate the two (2) yellow wire connections, large and small, on the right hand side of the Mechanism Panel. These control the Sold-Out Lights. Disconnect both.
- C.) Remove the Mechanism Panel by first loosen the three (3) Silver Screws on the bottom of the Mechanism

Figure 5 Inside view of Driver Mechanism

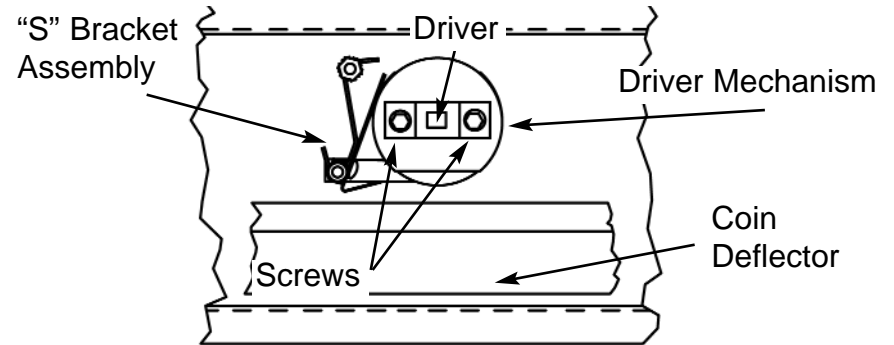
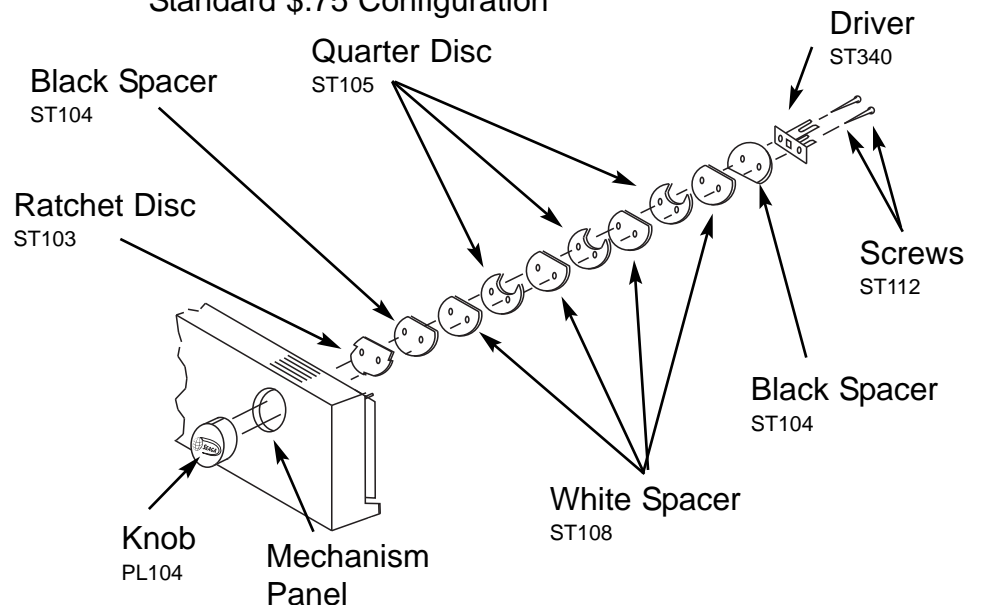

Figure 6 Coin Mechanism exploded view Standard \$.75 Configuration



Panel and remove the three (3) Silver Screws on the top of the Mechanism Panel.

D.) Pull the Mechanism Panel outward. Carefully free Drivers from all Can Spiral Coils.

E.) Turn desired Mechanism Knob clockwise ¼" turn and place Mechanism Panel face down on a flat surface, exposing the Driver Mechanism and "S" bracket assembly. (Fig. 7)

Note: Change one Driver Mechanism at a time.

F.) To change Driver Mechanisms, remove two (2) nuts (Fig. 5) and gently remove "S" Bracket Assembly.

G.) Unscrew and remove the two (2) Screws holding Driver to the Coin Sub-Assembly. (Fig. 5 Fig. 6)

H.) Coin Sub-Assembly (Fig. 4 & Fig. 6) will come apart from Knob, and can be carefully removed.

2. To assemble Driver Mechanism:

A.) Lubricate backside of Mechanism Panel around holes with a small amount of petroleum jelly.

B.) Insert two (2) screws through Coin Sub-Assembly to Knob. Make sure Knob is seated properly and tighten screws into place. If handle is hard to turn, loosen the two (2) screws 1/8 to 1/4 turn.

C.) Turn mechanism Knob to align Coin Discs with "S"

Figure 7 "S" Bracket Assembly

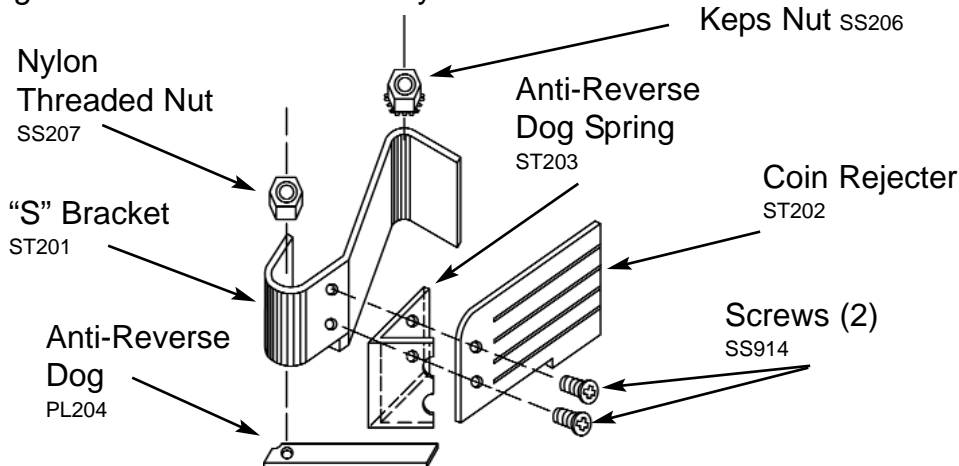

A.) Unlock and open the Front Door.

B.) Load Product Display Shelf to correspond with its Column.

Note: To present your product in as an attractive and professional manner as possible, do not load any damaged items, and make sure items are facing forward for easy identification by your customer.

COIN RETRIEVAL

One (1) Coin box is provided with your BV155. It is stored in the bottom of the Mechanism Panel. Once the Front Door is open, pull out the Coin Box to the right to empty it.

CLEANING THE CONDENSER

Dust and dirt restricts good airflow and function of the condenser and causes the refrigeration unit to not chill properly. It is extremely important to keep your condenser clean. First, unplug your vendor from its power source. Locate the inlet vent for the condenser on your machine Brush the dirt and dust from the condenser and grill. Locate the exhaust opening for the cooling system. Blow air on the condenser or vacuum clean it. Do not damage the fins of the condenser while cleaning. Depending on your location, your grill and condenser may need to be cleaned as often as once a week, but should be checked regularly.

GENERAL NOTES

It is suggested that a toolbox accompany you to each of your locations. Suggested items for this toolbox would include a socket set, (up to a 1/2" socket size suggested) a Phillips and a Standard screwdriver. Additional items would be a soft rag and perhaps a Black Magic marker. The magic marker is useful in touching up light scratches that may occur to your vendor.

COMMON QUESTIONS AND ANSWERS

COIN MECHANISM

Q: My knob turns without coins.

A: Your Coin Rejecter is loose, misaligned or broken. Refer to

- A.) Unlock and open the Front Door.
- B.) Remove all product from vendor.
- C.) Remove the Mechanism Panel per Access Coin Mechanism, Page 6, steps A through D.
- D.) On the panel directly above the vend area, remove the four (4) mounting screws, and remove panel.
- E.) Remove the ten (10) mounting screws at the front edge of the Column Assembly. There are two (2) mounting screws per Column. (Fig. 3)
- F.) Pull the Column Assembly forward to remove.

2. To Replace a "Sold-Out" Switch.

- A.) Follow steps A through E above.
- B.) Pull the Column Assembly forward about 12".

Note: The "Sold-Out" Switch is held in place by two (2) Rods (Fig. 3). These Rods are held by Clips.

- C.) With a pair of Pliers carefully remove the Clips from the side of the Column Assembly closest to the desired "Sold-Out" Switch.
- D.) Slowly remove the Rods until the desired "Sold-Out" Switch is free.

Note: There are plastic wire ties on the rods near each "Sold-Out" Switch, these are part of the assembly process and do not need to be present.

- E.) Disconnect the wires from the "Sold-Out" Switch. (Fig.3)
- F.) Attach wires to new "Sold-Out" Switch, black wire on top, white wire on the bottom.
- G.) Reassemble. Make sure that all "Sold-Out" Switches are centered in the openings of the Product Chute.

PRODUCT VIEWING AND ADVERTISEMENT

Your Beverage Vendor features "live" product display. This means that your customers will see actual cans of the product your vendor is offering.

- 1.) Set-Up of "Live" Display.

- bracket mounting studs. Install "S" bracket assembly over mounting studs. Do not install the nuts yet.
- D.) Now turn Mechanism Knob so Coin Disc slots are facing down. The Anti-Reverse Dog can now be raised enough to enable the Anti-Reverse Dog Spring to seat under the Anti-Reverse Dog. At the same time the "S" bracket assembly will be seated against Mechanism Panel. Place Keps Nut on upper mounting stud. (DO NOT TIGHTEN NUTS.) (Fig. 4 & Fig. 6)
- E.) Turn Knob to align coin discs with "S" bracket assembly, once again. Use a screwdriver to push top of "S" bracket assembly fully to right and tighten Keps Nut. You may now tighten Nylon Threaded Nut to lower mounting stud. (DO NOT OVER TIGHTEN.)

Note: The fingers of the Coin Rejecter must align with Coin Discs of the Coin Sub-Assembly. The Coin Discs strike the center of each finger to prevent vending without coins. **This alignment is critical.** If the fingers are misaligned the vendor will not vend. (Fig 8)

Figure 8 Proper Finger Alignment

Figure 8a Accepted!
Coins should push the fingers out. Make sure coins contact the center of the fingers.

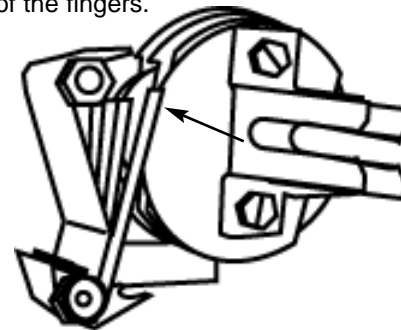
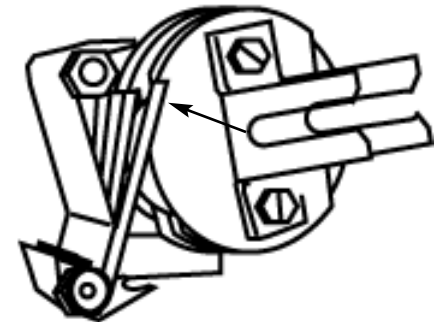

Figure 8b Vend!
Accepted coins push the fingers over the Coin Discs' catches to vend.



LOADING PRODUCT

Product is loaded horizontally, it makes no difference, which way the product lid faces. Each selection will hold 31 cans, for a total capacity of 155 cans.

To maximize capacity, the Product Chutes are specially designed for compact space. It is important to follow these steps to ensure proper loading.

1. Initial Load of the Product Chutes.

- A.) Unlock and open the Front Door.
- B.) Tilt open the Insulation Panel.
- C.) Load four (4) cans into the lowest Product Chute.
- D.) Load two (2) cans into the second Product Chute.
- E.) Load one (1) cans into the third Product Chute.
- F.) Load one (1) can into the top Product Chute.

This will hold all Gates closed.

- E.) Load product into any Chute until the Column is full.

Note: The lower three (3) Product Chutes have Gates on them that are held closed by product in the rear vertical Chute, (Fig. 9) if the Gate is propped open by product, then a jam could occur. While you can load the top Product Chute first to fill the rear vertical Chute, the first few cans loaded will be shaken and could spray when opened.

2. Reloading of the Product Chutes.

Figure 9 Initial Loading

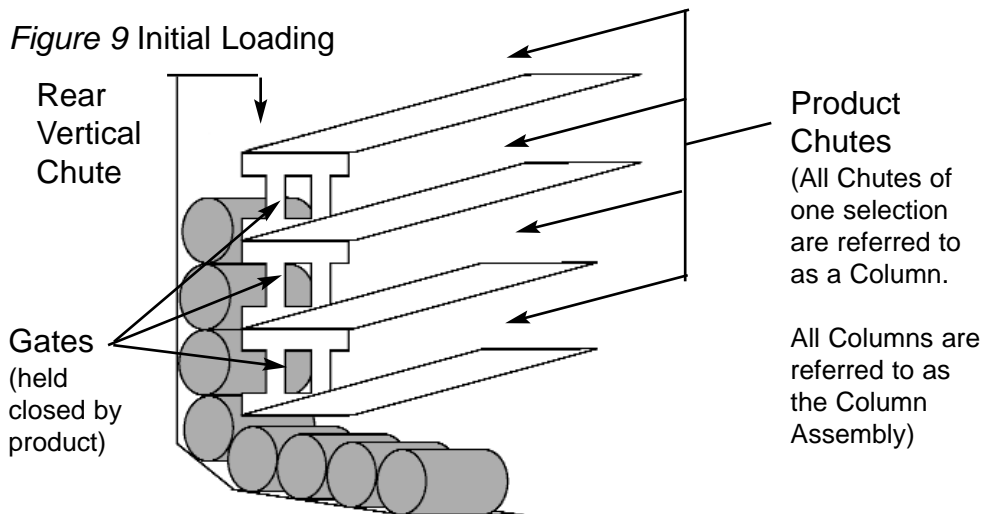

- A.) Unlock and open the Front Door.

- B.) Survey how much product remains in each Column.

Note: It is important that the rear vertical Product Chute is filled first to close all Gates.

- C.) If lower 3 chutes are full, load cans in top chute until full.

- D.) If any of the lower 3 chutes are empty or are not completely full, vend or remove the cans from the uppermost chute with product remaining in it. Once the gate at the back of that chute is down or closed, load cans in the top chute until the rear vertical chute is full. Then load cans in any chute until all columns are full.

Figure 10 Fully Loaded Column

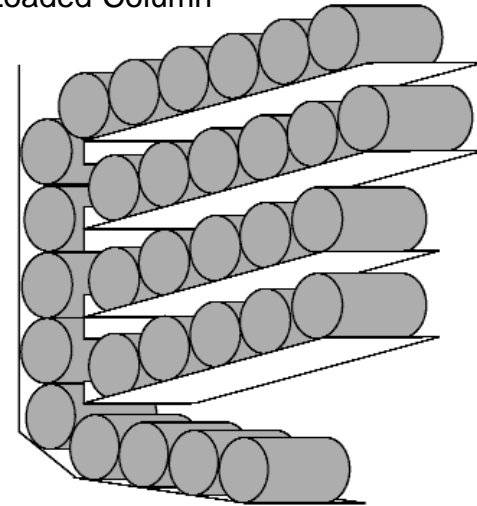

Special Note: We suggest that you always partially fill the vendor with product and perform at least five (5) test vends for each selection. Always use cans that are free from defects and foreign matter. Glue deposits from 12 packs are a common cause of cans failing to roll properly.

COLUMN ASSEMBLY

In rare cases it may be necessary to remove the Column Assembly. Such cases may include cleaning after product spills in the vendor, or the replacement of a "Sold-Out" Switch.

1. To Remove the Column Assembly.