



**HF2000    HF3000**  
**HF2500    HF3500**



# Operator's Manual

Seaga Manufacturing, Inc.  
700 Seaga Drive  
Freeport, IL USA 61032  
[www.seagamfg.com](http://www.seagamfg.com)

# The Elite Automatic Series Vendor

## INTRODUCTION

This manual is divided into three (3) main sections, Elite Snack Vendor, Money Mechanisms, and Elite Beverage Vendor. This manual focuses on the HF3500 as it is the largest of the series, there will be points that apply only to the HF3500, and those items will be identified for clarity.

## IMPORTANT NOTICES

Your vendor(s) are intended for indoor use only.

Your vendor(s) must be set on a level, well-supported location.

**If you have a combo snack and soda HF2500 or HF3500, your vendor has two (2) power cords. Both cords must be plugged in for full function of the machine.**

Leave at least 6" (15 cm) between the left-hand side of the vendor and wall.

Leave at least 6" (15 cm) between the back of the vendor and wall.

Condenser cooling air is taken in the left and exhausted out the back.

Always unload vendor before transporting it.

Do not load your vendor with disfigured or damaged product.

Temperature is factory set. Allow your vendor(s) to operate for twenty-four (24) hours before attempting any adjustments.

**Always disconnect electrical supply to BOTH snack and beverage units before servicing the machine.**

## Section 1

### ELITE SNACK VENDOR

#### Elite Snack Vendor HF3000

(HF2000 Not Shown)

Note: HF2000 has only two (2) Product Trays

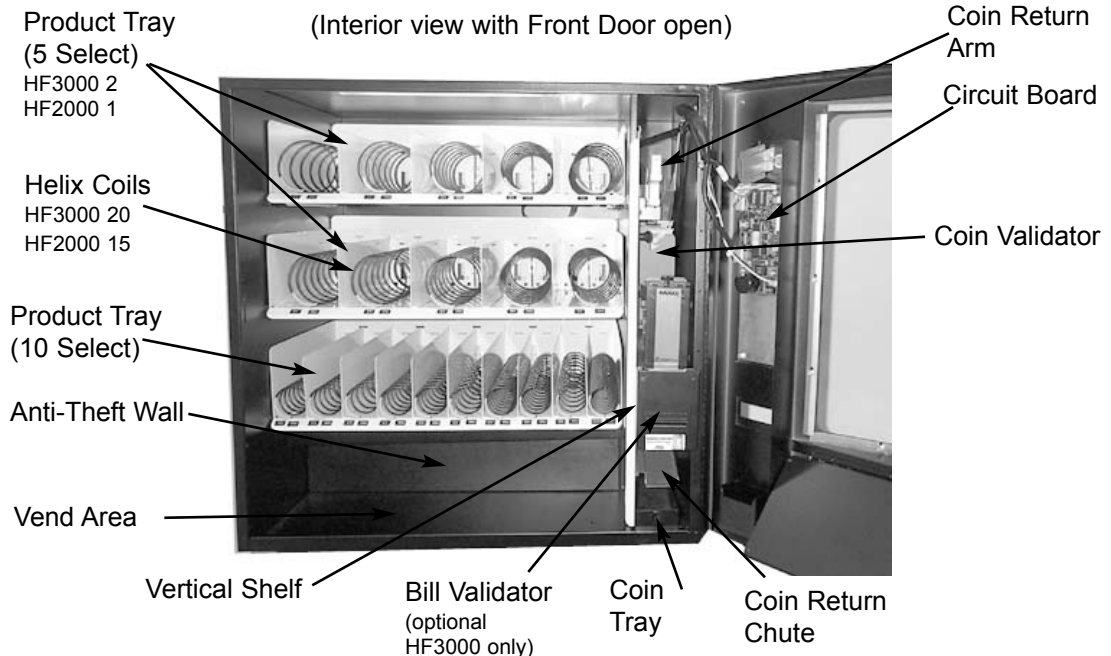
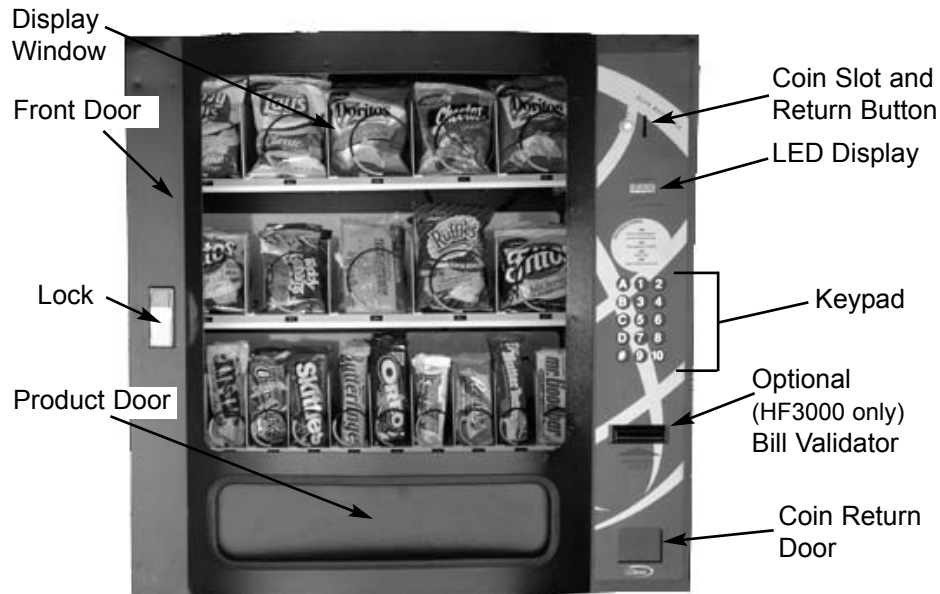

## **LOCK**

Your Elite Snack Vendor has one Lock, more commonly known as a "T" handle Lock. To unlock the Front Panel, insert key and turn clockwise ¼ turn. When unlocked the "T" of the Lock will pop out from the vendor. Turn ¼ turn clockwise to open Front Panel.

## **MOUNTING**

Your Elite Snack Vendor can be mounted to either an optional Stand or to the Elite Beverage Vendor. The optional Stand comes pre-assembled, with mounting hardware. You will need tools for mounting.

1. To Mount to optional Stand.

- A. Unlock and open Stand.
- B. Set vendor on top of Stand.
- C. Unlock and open Front Door.
- D. Remove bottom Product Tray. Pull Product Tray fully forward, keeping it level.
- E. Lift Product Tray to release from the track. Then it can be pulled forward and lifted out.

CAUTION: The Product Tray Wire Harness will need to be unplugged prior to complete removal of the Product Tray. The Wiring Harness is plugged into the inside right-hand side of the vendor. You may need assistance.

- F. Set back of Product Tray into Vend area, steady it with one hand, and disconnect the Wiring Harness.
- G. Attach Stand to bottom of vendor. Insert 3 bolts down through the vendor into welded nuts in the top of the Stand. Tighten. (Fig. 1)
- H. Reinstall product tray.

Mounting to the optional Elite Beverage Vendor will be explained in that section of this manual.

## **LEVELING**

Once your vendor is in its new location, you will need to level it to insure proper operation. You will need a level. We recommend a 3ft (1m) level, as it will give a more accurate reading than a small torpedo level. There are threaded Levelers included with your vendor. These Levelers screw into the bottom of your Stand and can then be adjusted up or down as needed.

## **ELECTRICAL CONNECTION**

The Elite Snack Vendor requires one (1) 120 VAC grounded outlet for each vendor(s).

Elite Snack Vendor	120 Volts	Less than 1 Amp
--------------------	-----------	-----------------

## **KEYPAD AND LED DISPLAY**

The Keypad (Fig. 2) is a touch sensitive operation. Light pressure will be necessary to activate each number or letter. The vendor's Keypad is used by the customer to make their selection, and by the operator to set and test many functions of the vendor.

The LED Display shows the customer the amount of money entered into the vendor, and the cost of their selection, it shows the operator the Service Mode functions for setting and testing the various functions of the vendor.

1. To Access Operator Functions:

- A.) Unlock and open the Front Door to access the Circuit Board, and enter Service Mode by pressing the Red Service Mode Button. (Fig. 3)

Figure 1 Optional Stand Mount

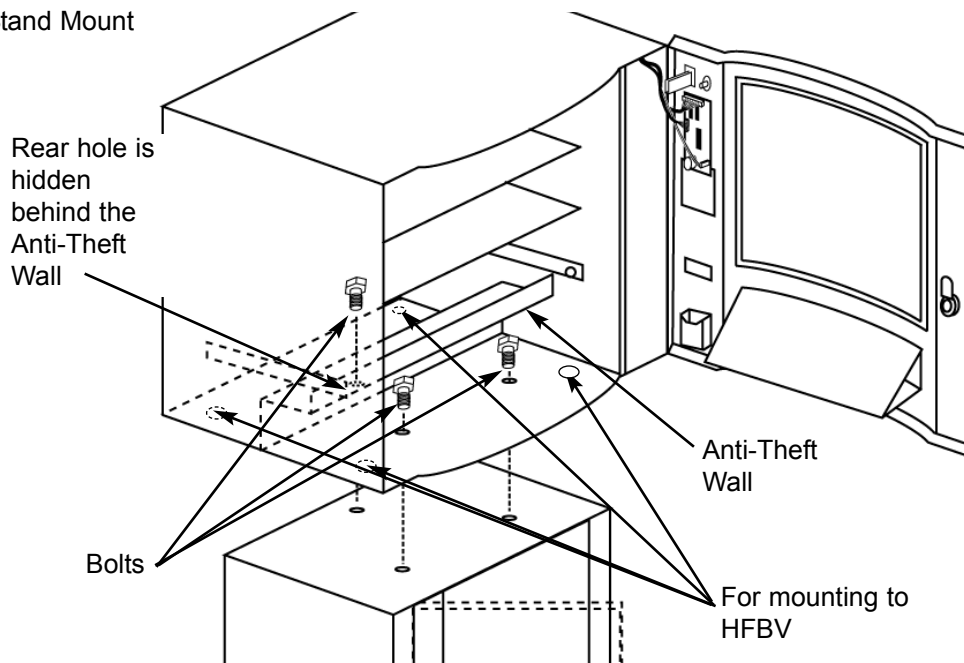

Figure 2 Keypad Layout

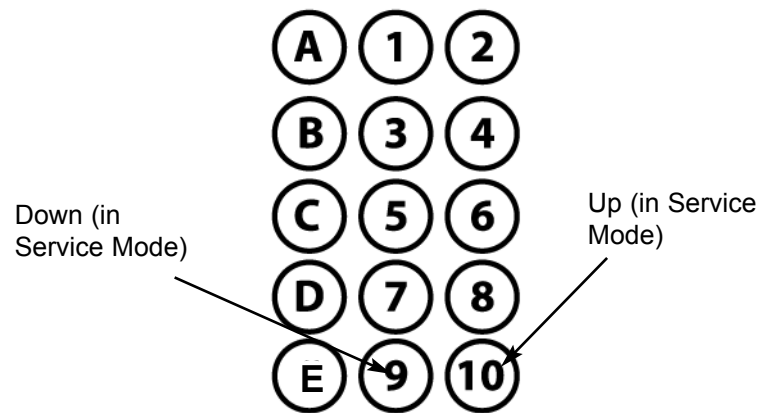

Figure 3 Service Mode Button

(Circuit Board inside Front Panel)

Wire Harness

Red Service Mode Button



**NOTE:** when plugging in wire harnesses after servicing, be aware that the side of the wire harness plug that shows silver connectors always face the outside edge of the circuit board or see below for color chart.

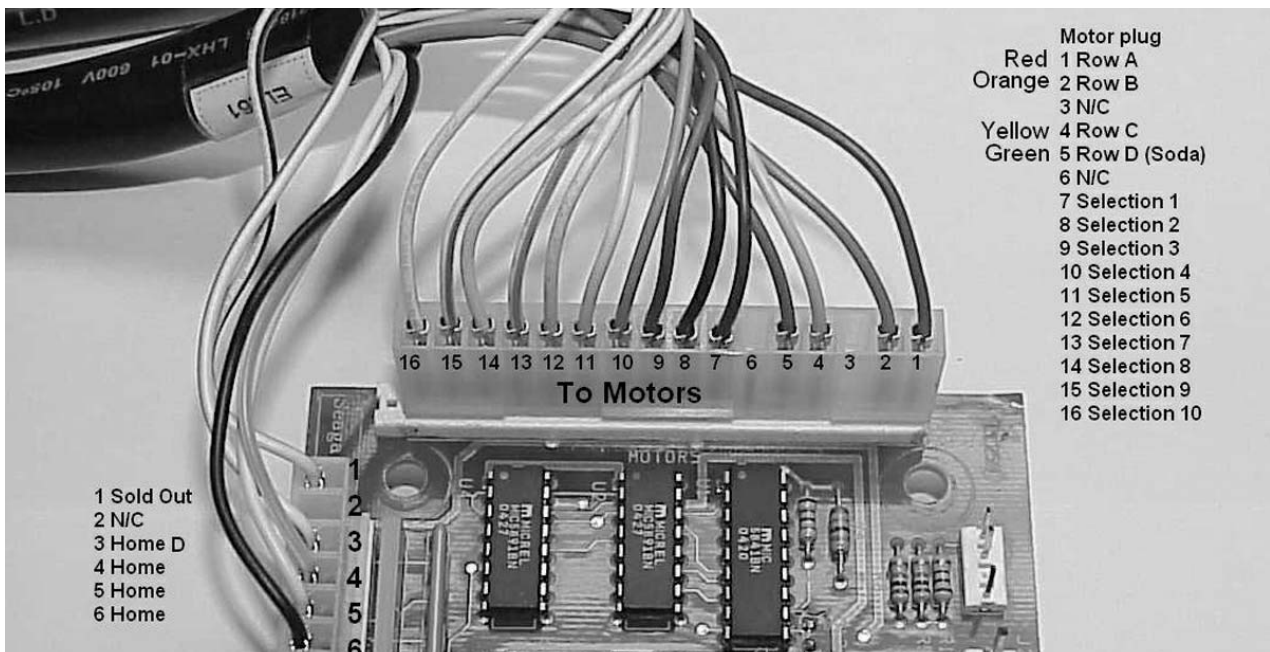

(The following information is repeated, for your convenience, on a sticker inside the vendor.)

## **SERVICE MODE**

The Service Mode is entered and exited by pressing the Red Service Mode button on the Circuit Board. All Service Mode functions are cycled and selected by pressing the DOWN (9) and UP (10) keys. If no action is taken within 20 seconds the display will return to Standard Operating Mode.

**MOTOR COUNT** ("Cnt")-displays the total count of motors available in this vendor.

Enter Service Mode. Cycle through the Service Mode until the display reads "Cnt". Press any keypad character other than the DOWN (9) or UP (10) key and the controller will display the motors it recognizes. The total number of motors should equal the total number of selections.

**BILL ESCROW** ("ES")-optional setting that when ON will return the bill to the customer on demand, when OFF the vendor will return coins to the customer.

Enter Service Mode. Cycle through the Service Mode until the display reads "ES". Press any keypad character other than the DOWN (9) or UP (10) key to turn this mode ON ("ES y") or OFF ("ES n").

**MULTI-VEND MODE** ("UL")-optional setting that when ON allows more than one vend to be performed, provided there is still credit remaining.

Enter Service Mode. Cycle through the Service Mode until the display reads "UL". Press any keypad character other than the DOWN (9) or UP (10) key to turn this mode ON ("UL y") or OFF ("UL n").

**FORCE-VEND MODE** ("FC")-optional setting that when ON requires a purchase once credit has been deposited.

Enter Service Mode. Cycle through the Service Mode until the display reads "FC". Press any keypad character other than the DOWN (9) or UP (10) key to turn this mode ON ("FC y") or OFF ("FC n").

**BEVERAGE SOLD-OUT MODE** ("Can")-optional setting that when ON operates sold-out function for the soda portion of this vendor, and will flash "Make Alternate Selection" when column is empty.

Enter Service Mode. Cycle through the Service Mode until the display reads "Can". Press any keypad character other than the DOWN (9) or UP (10) key to turn this mode ON ("Can y") or OFF ("Can n"). Press "A" to save your choice.

**TEST ALL MOTORS** ("Test")-allows user to test all motors in your vendor.

Enter Service Mode. Cycle through the Service Mode until the display reads "Test". Press any keypad character other than the DOWN (9) or UP (10) key to test all motors. No other function can be accessed during the test. The time this function requires will vary, as each motor will complete one revolution.

**INDIVIDUAL MOTOR TESTING** ("Sict")-allows user to individually test each motor in this vendor.

Enter Service Mode. Cycle through the Service Mode until the display reads "Sict". Enter any selection to test it's motor. (ex. A1)

**PRICE SETTING** ("Prc")-allows the user to set individual prices for each motor or item loaded in your vendor.

Enter Service Mode. Cycle through the Service Mode until the display reads "Prc". Enter any selection to display current price. (ex. A1) Press the DOWN (9) or UP (10) key to change the price for that selection. Price settings will change in 5 cent increments. Press "A" to save the new price.

**CASH HISTORY** ("Cash")- displays total cash count.

Enter Service Mode. Cycle through the Service Mode until the display reads "Cash". Press any keypad character other than the DOWN (9) or UP (10) key to display the total cash count the vendor has accumulated. This function cannot be reset to zero.

**SALES HISTORY** ("Sale")-displays total vend count.

Enter Service Mode. Cycle through the Service Mode until the display reads "Sale". Press any keypad character other than the DOWN (9) or UP (10) key to display the total vend count that your vendor has performed. This function cannot be reset to zero.

**COIN DISPENSING** ("Coin")-allows user to manually dispense coins from the Coin Mechanism by coin type.

Enter Service Mode. Cycle through the Service Mode until the display reads "Coin". Pressing keys 1-7 will dispense the lowest through the highest denomination of coins. For American Coin Mechanisms key 1 will dispense nickels, key 2 will dispense dimes, and key 3 will dispense quarters.

**Special Note:** To avoid true customer aggravation, Multi-Vend and Force-Vend should NOT be turned on at the same time.

## **DELIVERY SYSTEM**

The Delivery System of your Elite Snack Vendor consists of the Keypad, LED Display, Driver Motors, Product Trays, Product Chutes, and Helix Coils. The customer inserts money and enters their selection on the Keypad. The selection's Driver Motor turns the Helix Coil that vends the product.

## LOADING PRODUCT

To present your product in as an attractive and professional manner as possible, do not load any damaged items, and make sure items are facing forward for easy identification by your customer.

**Note:** The size of the item being vended must be larger than the Helix Coil, but smaller than the Column, to vend correctly. Never force an oversized item into the Helix Coil or Column, nor attempt to vend an item that is smaller than the Helix Coil as this will create problems and deter customers. (Fig.4)

1. To Load Product:

A.) Pull out desired Product Tray all of the way forward. Product Tray will tilt down.

**Note:** Pull out only one (1) Product Tray at a time.

B.) Place product in proper size Helix Coil.

**Note:** Bottom of product must rest on the Product Tray and not on the Helix Coil. (Fig. 4)

Load each Column from front to back.

*Figure 4 Loading Product*

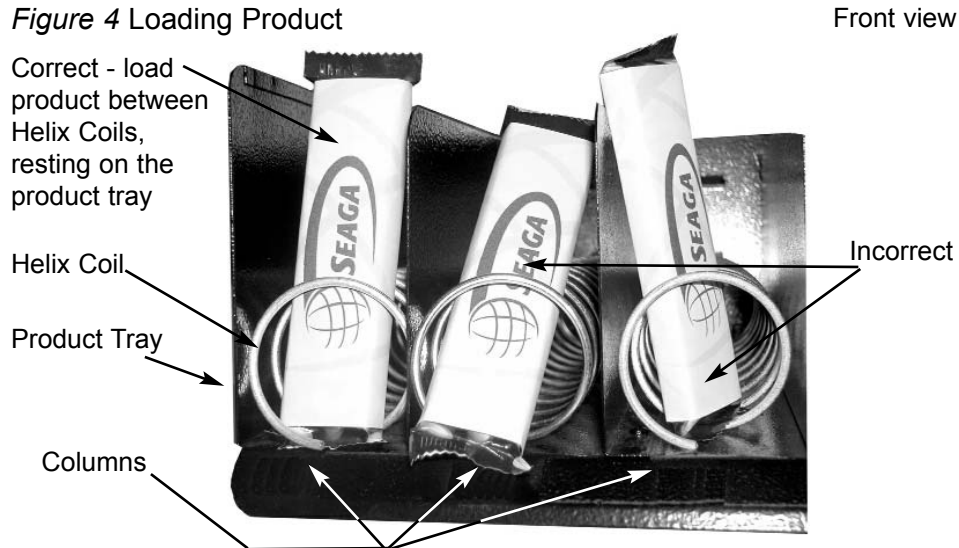

**Note:** Fill all Product Trays fully, do not leave any spaces behind or between items.

C.) Once Product Tray is fully loaded, lift and push it back in.

Repeat above steps until all Product Trays are fully loaded.

To increase the length of the Helix Coil, white plastic Product Pushers can be snapped on the end. A supply of Product Pushers are provided in the vendors hardware bag.

**Special Note:** We suggest that you always partially fill the vendor with product and perform at least five (5) test vends. Test vends can be performed easily by entering Service Mode and running "Individual Motor Testing". (See: Keypad and LED Display, Individual Motor Testing.)

## DRIVER MOTORS

Each selection is vended by the action of the Driver Motor. The HF3000 has 20 Driver Motors and the HF2000 has 15. The Driver Motors are clipped to the rear of each Product Tray.

In the rare event of a jam a Driver Motor may need to be returned to its home position. The home position is when the shaft of the Helix Coil that is held by the Driver is vertical, with the end of the shaft pointing down. (Fig. 5)

1. To "Home" a Driver Motor.

A.) Unlock and open the Front door to access the Circuit board, and enter Service Mode by pressing the Red Service Mode Button (Fig. 3)

*Figure 5 Delivery System*

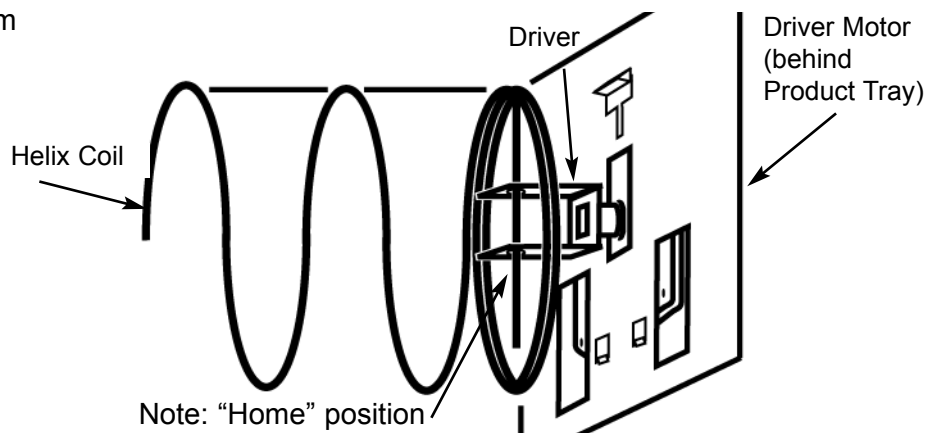

B.) Cycle through the Service Mode until the display reads "SLCT".

C.) Enter the letter and number of the motor you wish to home. The motor will rotate to it's home position.

2. To Remove a Driver Motor.

A.) Unlock and open Front Door

B.) Pull Product Tray fully forward, keeping it level.

C.) Lift Product Tray to release from the track. Then can be pulled forward and lifted out.

**Caution:** The Product Tray Wire Harness will need to be unplugged prior to complete removal of the product tray. The Wiring Harness is plugged into the inside right-hand side of the vendor. You may need assistance.

D.) Set back of Product Tray into Vend area, steady it with one hand, and disconnect the Wiring Harness.

E.) Remove Helix Coil from Driver by lifting the front end of the Helix Coil up with one hand while guiding the rear of the Helix Coil with the other.

**Note:** This operation is more difficult with the smaller Helix Coils.

F.) Depress the top tab on the Driver Motor, tilt the Driver Motor backwards, and lift the Driver Motor free. (Fig. 7)

G.) Disconnect Wires.

H.) Replace Driver Motor by repeating above steps in reverse order.

Figure 6 Driver Motor

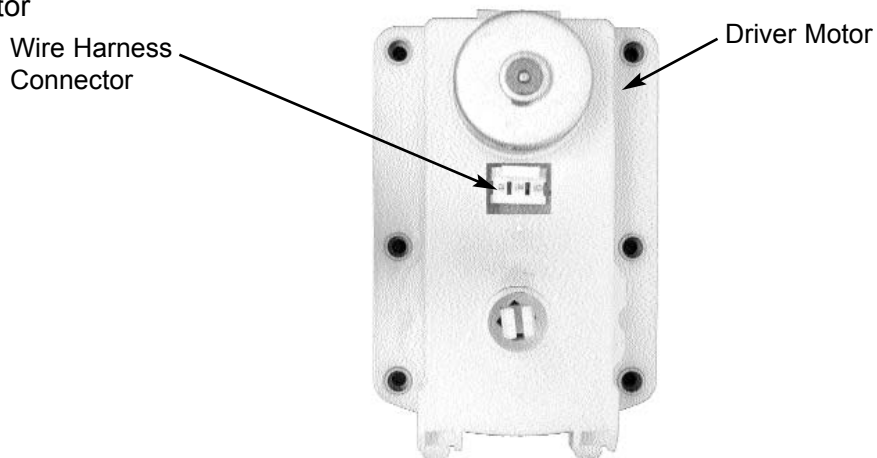
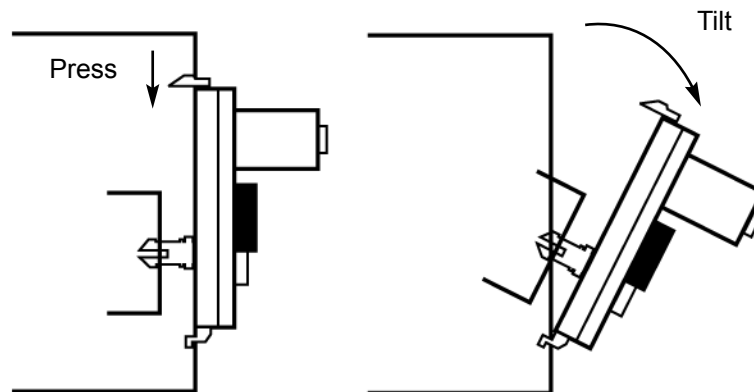

Figure 7 Motor Removal



**GENERAL NOTES**

It is suggested that a toolbox accompany you to each of your locations. Suggested items for this toolbox would include a socket set, (up to a 1/2" - 12 mm - socket size suggested) a Phillips and a Standard screwdriver and needle nosed pliers. Additional items would be a soft rag and perhaps a Black Magic marker. The magic marker is useful in touching up light scratches that may occur to your vendor.

**COMMON QUESTIONS AND ANSWERS**

Q: How high can I set my prices?

A: Each selection can be individually priced up to \$95.95.

Q: Can customers reach up and help themselves to product?

A: No. The Product Door is a Triangle shape designed to deter reach up theft. When pushed, the back of the door will come in contact with the bottom Product Tray and the Anti-Theft Wall to act as a block.

- Q: My vendor is plugged into a live outlet, I have tested the outlet, but my vendor has no power.  
 A: Unplug the vendor for 5 minutes. This will reset the thermal breaker on the transformer.
- Q: Motor does not cycle.  
 A: Check the Wire Harness on the motor for a loose wire.  
 Check to see if the motor is jammed or out of home. Home the motor per "Driver Motors".
- Q: When I make a particular selection, the display reads "fail".  
 A: Perform the "Motor Count" per "Keypad and LED Display" Pg.6. If the number of Driver Motors found, matches the total number of selections, check the wiring connections at the Driver Motor and the Circuit Board.
- Q: Motor cycles but product will not drop.  
 A: Check to see if the product is jammed in the Product Chute.  
 Check to see if the vendor is level.  
 Check product for damage, and make sure it is the proper size.  
 Install Product pushers on the ends of the Helix Coils to assist in vending.
- Q: In the event of a power outage, will I have to reprogram my vendor?  
 A: No. Your selection prices are safely stored.

**Section 2**  
**PAYMENT SYSTEMS**

**COIN VALIDATOR**

**Note:** The manufacturer's Coin Validator manual is packed with your vendor. The following is intended as an addendum to the manufacturer's manual.

**Elite Snack Vertical Shelves with Payment Systems**

HF2000

HF3000

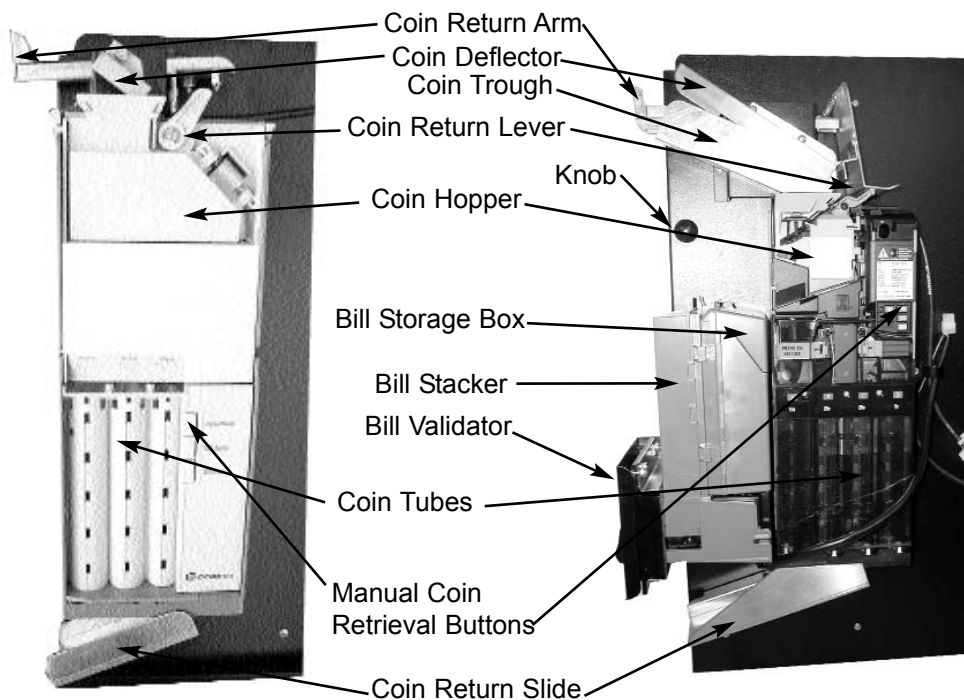

The Coin Validator receives and returns change to your customers. The Coin Validator is installed at the factory, and will accept quarters, dimes, and nickels. The Coin Validator can be set to accept the new golden dollar. Coins that are not needed to maintain inventory in the Coin Tube, and all other coins are diverted to the Coin Tray. It is recommended that you initially load the tubes at least half full when setting up your vendor and that you not allow your vendor's coin inventory to drop below that.

### **COIN RETRIEVAL**

Coins can be retrieved from the vendor in three (3) ways; the Coin Tray, Manual Coin Retrieval Buttons, and the Coin Return Button. The Coin Tray sits below the Vertical Shelf. The Coin Tray holds all accepted coins, except for those needed to maintain inventory in the Coin Tubes. (Some overflow may occur if not emptied periodically.) The Manual Coin Retrieval Buttons are along side the Dime Tube, pressing a button will dispense one (1) of the selected coins. With the Vertical Shelf pulled out, you will need to catch the coins as they are dispensed to the coin return slide. The Coin Return Button moves the Coin Return Arm, and pushes the Coin Return Lever returning coins to the customer that have been inserted.

### **CAPACITY**

If you intend to vend high-ticket (over \$1) items through your vendor, or the vendor is in a high traffic area, you may want to set the Coin Validator to maintain a full Quarter Tube. The Bill Validator will not accept \$5 bills unless the quarter tube is nearly full. Refer to the manufacturer's manual to adjust option switch settings.

### **BILL VALIDATOR**

**Note:** The manufacturer's Bill Validator manual is packed with your vendor. The following is intended as an addendum to the manufacturer's manual.

The optional Bill Validator (HF3000 only) allows your customers to pay for their purchase with paper currency. Your optional Bill Validator is installed at the factory, and is set to validate \$1, \$2, and \$5 bills, but will not accept \$2 and \$5's unless the Coin Chutes are nearly full. The Bill Validator can be set to also accept \$10, and \$20 bills. Unless you intend to vend high-ticket specialty items from your vendor, your Bill Validator need not accept \$10 and \$20 bills.

*Figure 8* Bill Validator

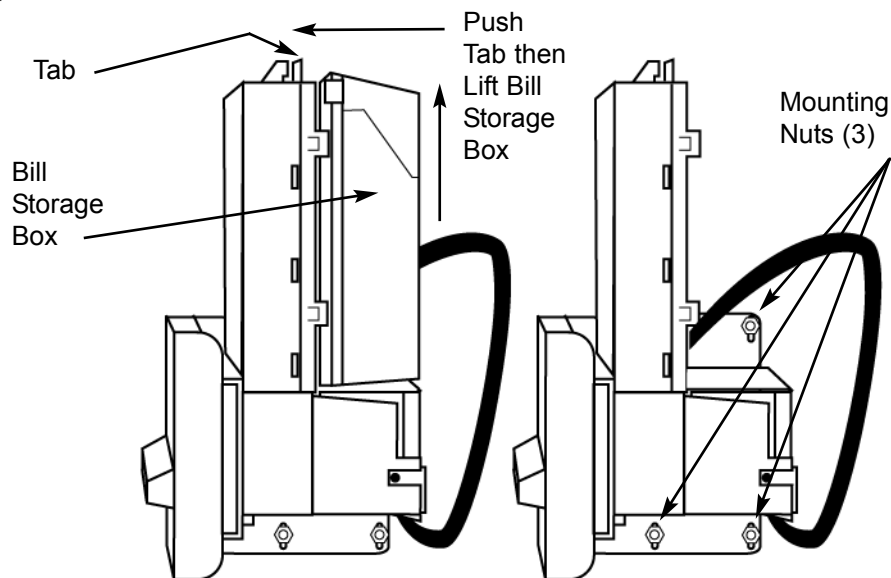

### **CAPACITY**

The Bill Storage Box will hold approximately 300 bills.

### **BILL RETRIEVAL**

The bills your customers spend are kept in the Bill Storage Box.

1. To Retrieve Bills.
  - A.) Unlock and open the Front Door.
  - B.) Pull the Vertical Shelf out.
  - C.) Pull Tab forward and lift Bill Storage Box. (Fig. 11) Remove bills.
  - D.) Return empty Bill Storage Box.

### **REMOVING BILL VALIDATOR**

From time to time it may be necessary to remove the Bill Validator for cleaning and clearing jams.

1. To remove the Bill Validator.
  - A.) Unlock and open the Front Door, unplug vendor.
  - B.) Pull the Vertical Shelf out.
  - C.) Pull Tab forward and lift Bill Storage Box.
  - D.) Disconnect Bill Validator from Wiring Harness.
  - E.) Remove the three (3) Mounting Nuts. (Fig. 8)
  - F.) Remove Bill Validator and mounting bracket.

## **CLEARING JAMS**

It is possible that a torn or damaged bill can jam within the Bill Validator, putting it out of service.

1. To Clear a Jam.

A.) Remove Bill Validator as above.

B.) Press Tab on bottom of Bill Validator, and pull Lower Housing free. (Fig. 9)

*Figure 9* Lower Housing Removal

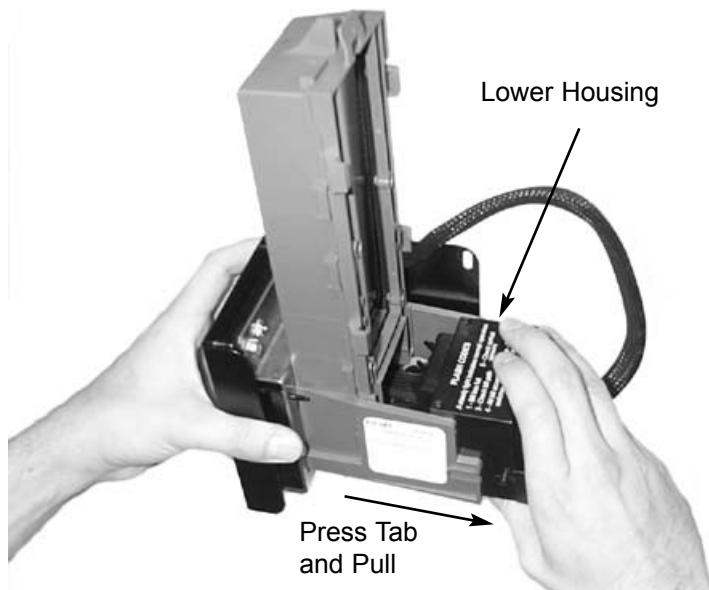

C.) Remove Jam, and reassemble.

## **CLEANING**

It is recommended that you clean your Bill Validator frequently to keep it in order. How frequently and how thoroughly you clean it will depend on the amount of traffic your vendor serves. Cleaning the Bill Validator can correct problems with service. There are three levels to the cleaning process. Cleaning with a Cleaning Card, cleaning the Optics, and washing the Lower Housing.

1. Cleaning with a Cleaning Card, will perform a basic clean. The vendor does not need to be opened. Seaga Manufacturing recommends CLEAN TEAM cards that can be obtained online at [www.cleanteam.com](http://www.cleanteam.com) or by calling 1-800-888-8830.

A.) Insert the cleaning card in the same manner you would a regular dollar bill, the card will be rejected. Do not re-use the card.

2. Cleaning the Optics is the second level of cleaning. You will need cotton swabs (Q-tips), and a mild soap and water solution.

A.) Remove the Bill Validator as described earlier in the manual.

B.) Remove the Lower Housing. There are three (3) Clear Lenses on the Lower Housing and three (3) Red Lenses inside the Bill Validator. (Fig. 10)

*Figure 10* Lens Cleaning

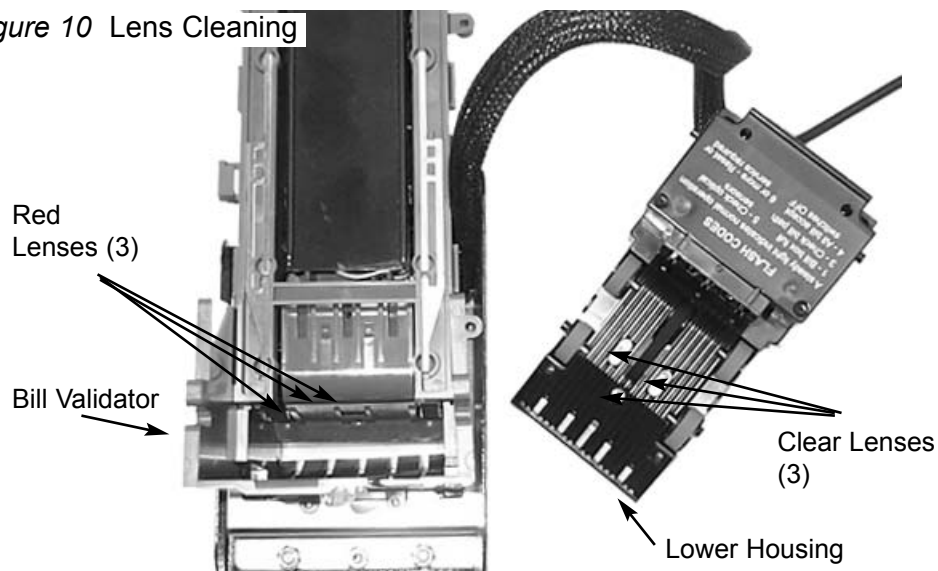

- C.) Swab the lenses with the solution, and reassemble.
3. Washing the Lower Housing is recommended at least once per year. You will need a mild soap and water solution and a cloth.
- A.) Remove the Bill Validator as described earlier in the manual.
  - B.) Remove the Lower Housing.
  - C.) Moisten the cloth. You will want the cloth moist, but not dripping.
  - D.) Wipe down the Lower Housing and the inside of the Bill Validator and reassemble.

### VERTICAL SHELF REMOVAL

1. To Remove the Vertical Shelf.
- A.) Unlock and open the Front Door, unplug vendor.
  - B.) Pull the Vertical Shelf out completely.
  - C.) Disconnect Wiring Harness to shelf.

*Figure 11 Vertical Shelf Removal*

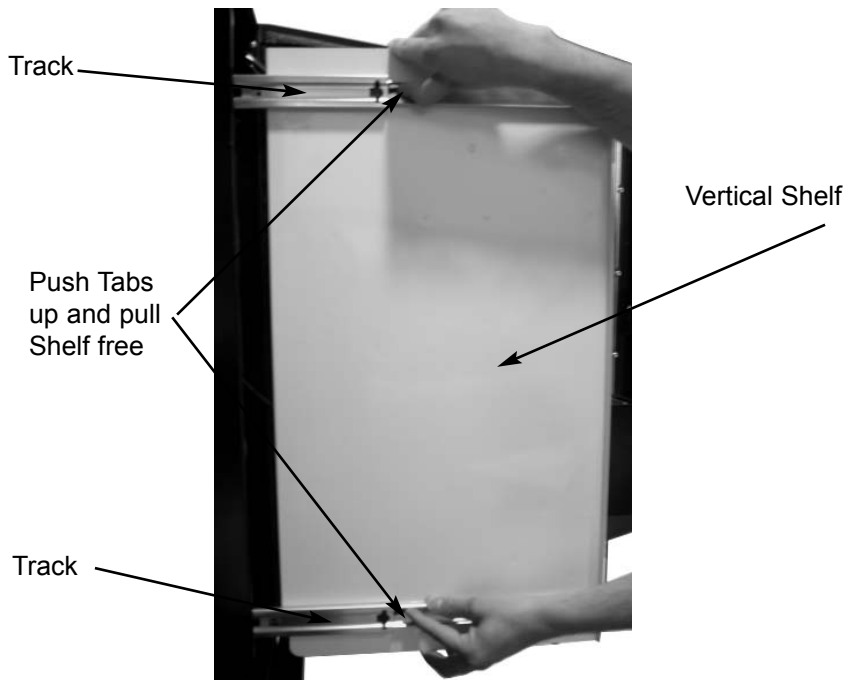

## SECTION 3 - ELITE BEVERAGE VENDOR

- D.) Push Tabs in both Tracks up, (Fig. 11) and pull Vertical Shelf free.

### COMMON QUESTIONS AND ANSWERS

- Q: Coin Validator will not accept coins.  
A: Lenses may be dirty.  
Coins may be damaged or worn.  
Wire Harness may not be connected properly.  
Coin Validator may not have power.
- Q: Optional Bill Validator will not accept bills.  
A: Stacker may be full.  
There may not be enough coins in the Coin Validator.  
Wire Harness may not be connected properly.  
Bill Validator may not have power.

### LOCK

Your Elite Beverage Vendor has one Lock, more commonly known as a "T" handle lock. This Lock is different from that of the Elite Snack Vendor in that it has a Threaded Stud that screws into the Cagenut. To unlock the Front Door, insert key and turn clockwise ¼ turn. When unlocked the "T" of the Lock will pop out from the vendor. Turn the Lock counter-clockwise until the Front Door opens. To lock, push Front Door closed and turn Lock clockwise until the Gasket is firmly engaged. **Note:** Do not over tighten, as you could damage the Lock and Gasket.

Elite Beverage Vendor  
HFBV

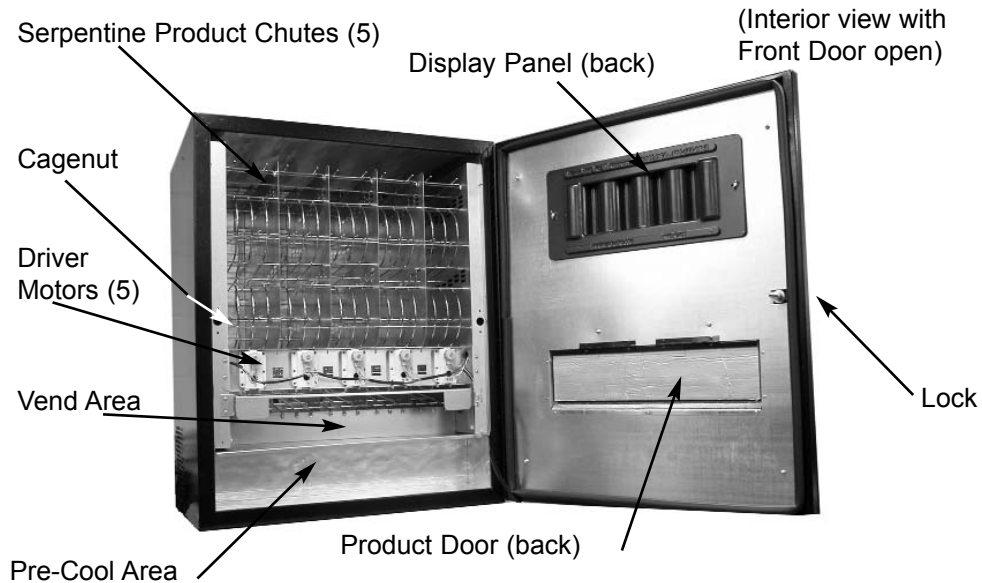
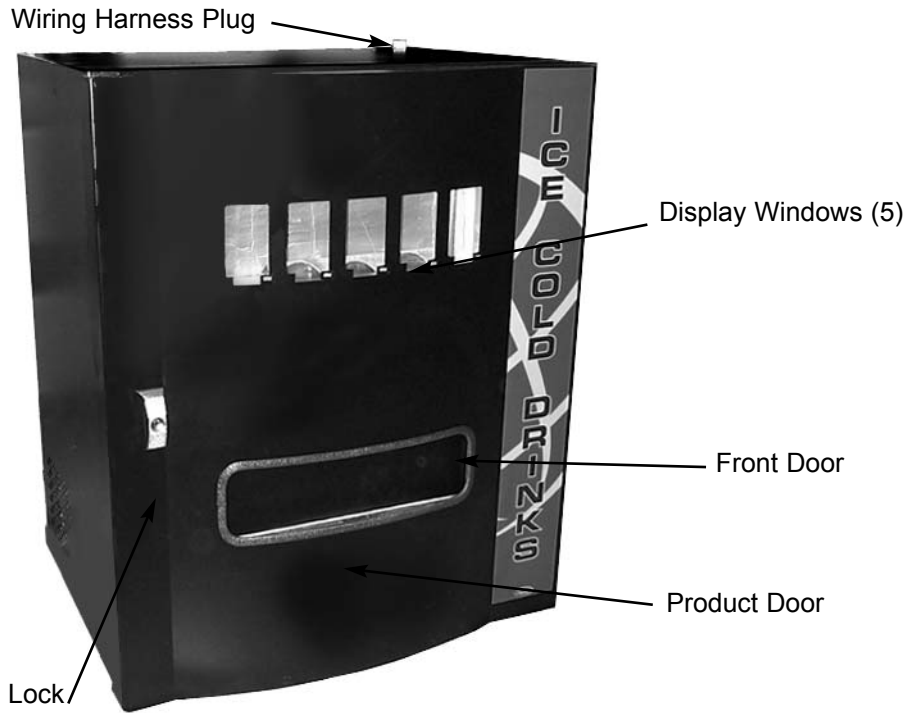

**ELECTRICAL CONNECTION**

The Elite Beverage Vendor requires one 120 VAC grounded outlet for each vendor(s).

Elite Beverage Vendor	120 Volts	4 Amps
-----------------------	-----------	--------

**TEMPERATURE CHECK**

Once your vendor is unboxed you will need to plug in your vendor and allow the vendor to come to operating temperature. We recommend that you perform this check prior to mounting the vendor to the Elite Snack Combo. It will take about 24hrs for the vendor to reach operating temperature of 38°- 45° F (3-7° C). Temperature fluctuation is normal, and will depend upon your local climate. **Note:** Never lay your vendor on its side. To adjust the temperature, turn the Adjustment Slot clockwise (1/8" - 3 mm - at a time) to a colder setting.

**MOUNTING**

Your Elite Beverage Vendor (HFBV) can be mounted to the Elite Snack Vendor to form the Elite Combo. The vendor comes with mounting hardware. You will need tools for mounting.

1. To Mount to the Elite Snack Vendor.

A.) Unplug both vendors.

B.) Set Elite Snack Vendor on top of HFBV, mating the Wiring Harness

Plug to the opening in the bottom of the Elite Snack Vendor.

**CAUTION:** Be careful not to damage the Wiring Harness Plug on top of the HFBV.

C.) Unlock and open the Front Door of the Elite Snack Vendor. The HFBV does not need to be opened.

(The following is to be done within the Elite Snack Vendor.)

D.) Remove bottom Product Tray. Pull Product Tray fully forward, keeping it level.

E.) Lift Product Tray to release from the track. Then it can be pulled forward and lifted out.

**CAUTION:** The Product Tray Wire Harness will need to be unplugged prior to complete removal of the product tray. The Wiring Harness is plugged into the inside right-hand side of the vendor. You may need assistance.

F.) Set back of Product Tray into Vend area, steady it with one hand, and disconnect the Wiring Harness.

G.) Attach the Elite Snack Vendor to the top of the HFBV. Insert 4 bolts down through the vendor into welded nuts in the top of the HFBV. Tighten. (Fig. 1)

H.) Remove Vertical Shelf per those instructions

I.) Connect Wiring harness plug from Elite Snack to HFBV.

J.) Reassemble Vertical Shelf and product tray.

### **PROGRAMMING**

Once your vendor is mounted and cooling properly you will need to perform an initial Test of all Motors to ensure that the electrical connections are properly made.

1. To Test Driver Motors.

A.) Unlock and open the Front Door to access the Circuit Board, and enter Service Mode by pressing the Red Service Mode Button. (Fig. 3)

B.) Cycle through the Service Mode until the display reads "Test".

C.) Press any keypad character other than the DOWN (9) or UP (10) key to test all motors. No other function can be accessed during the test. The time this function requires will vary. When complete, display will return to Standard Operating Mode.

**Special Note:** We suggest that you always partially fill the vendor with product and perform at least five (5) test vends, and test vend each selection. Test vends can be performed easily by entering Service Mode and running "Individual Motor Testing". (See: Keypad and LED Display, Individual Motor Testing.)

### **LEVELING**

Once your vendor is in its new location, you will need to level it to insure proper operation. You will need a level. We recommend a 3ft (1m) level, as it will give a more accurate reading than a small torpedo level. There are threaded Levelers included with your vendor. These Levelers screw into the bottom of your vendor and can then be adjusted up or down as needed.

### **DELIVERY SYSTEM**

The HFBV's Delivery System consists of the Keypad, LED Display, Serpentine Product Chutes, Driver Motors, and the Can Coil. The customer inserts money and enters their selection on the Keypad. The selection's Driver Motor turns the Can Coil that vends the product.

There is a sold out switch near the end of each Serpentine Product Chute that will turn on the "Choose Alternate Selection" function when it does not detect product. **Note:** When the Choose Alternate Selection light flashes, there will be two cans of product remaining in the Serpentine Product Chute.

### **LOADING PRODUCT**

Product is loaded horizontally at the top of the Serpentine Product Chute. It makes no difference, which way the product lid faces. Continue to load product until the Serpentine Product Chute is full. Each Serpentine Product Chute will hold 39 cans.

### **PRODUCT VIEWING AND ADVERTISEMENT**

Your Elite Beverage Vendor features "live" product display. This means that your customers will see actual cans of the product your vendor is offering.

1.) Set-Up of "Live" Display.

A.) Unlock and open the Front Door.

B.) Unscrew the two (2) wing nuts, and remove black molded plastic Display Panel.

C.) Load product to correspond with its Serpentine Product Chute.

**Note:** To present your product in as an attractive and professional manner as possible, do not load any damaged items, and make sure items are facing forward for easy identification by your customer.

D.) Return the Product Display Panel so that it is pressing against the displayed product, and reinstall the two (2) wing nuts.

### **CLEANING THE CONDENSER**

Dust and dirt restricts good airflow and function of the condenser and causes the refrigeration unit to not chill properly. It is extremely important to keep your condenser clean. First, unplug your vendor from its power source. Locate the inlet vent for the condenser on your machine (Fig. 14). Brush the dirt and dust from the condenser and grill. Locate the exhaust opening for the

cooling system. Blow air on the condenser or vacuum clean it. Do not damage the fins of the condenser while cleaning. Depending on your location, your grill and condenser may need to be cleaned as often as once a week, but should be checked regularly.

### **DRIVER MOTORS**

Each selection is vended by the action of the Driver Motor. The HFBV has 5 Driver Motors. The Driver Motors are clipped to the front of the Motor Bracket. (Fig. 12)

In the rare event of a jam a Driver Motor may need to be returned to its home position. The home position is when the shaft of the Can Spiral Coil that is held by the Driver is vertical, with the end of the shaft pointing up.

1. To "Home" a Driver Motor.

- A.) Unlock and open the Front door to access the Circuit board, and enter Service Mode by pressing the Red Service Mode Button (Fig. 3)
- B.) Cycle through the Service Mode until the display reads "SLCT".
- C.) Enter the letter and number of the motor you wish to home. The motor will rotate to it's home position.

2. To Remove a Driver Motor.

- A.) Unlock and open the Front Door, unplug vendor.
- B.) Unload any product from the Serpentine Product Chute in question.
- C.) Depress the top tab on the Driver Motor, rock the Driver Motor forward, and lift the Driver Motor free. (Fig. 7)
- D.) Disconnect Wires.
- E.) Replace Driver Motor by repeating above steps in reverse order.

**Note:** When inserting the Driver Motor make sure that the end of the Can Spiral Coil is pointed upward.

### **COMMON QUESTIONS AND ANSWERS**

Q: Motor does not cycle.

A: Check the Wire Harness on the motor for a loose wire.  
Check to see if the motor is jammed or out of home. Home the motor per "Driver Motors".

Q: Motor cycles but can will not drop.

A: Check to see if the can is jammed in the Product Chute.  
Check to see if the vendor is level.  
Check product for damage, and make sure it is the proper size.

Q: Cans occasionally stick in my Delivery System.

A: This is not uncommon. Some cans may have defects or foreign matter that may cause them to hesitate, resulting in delayed advancement of product.

Q: How does my HFBV know it's out of product?

A: There is a sold out switch near the end of each Serpentine Product Chute that will flash the Choose Alternate Selection light when it does not detect

*Figure 12 Delivery System*

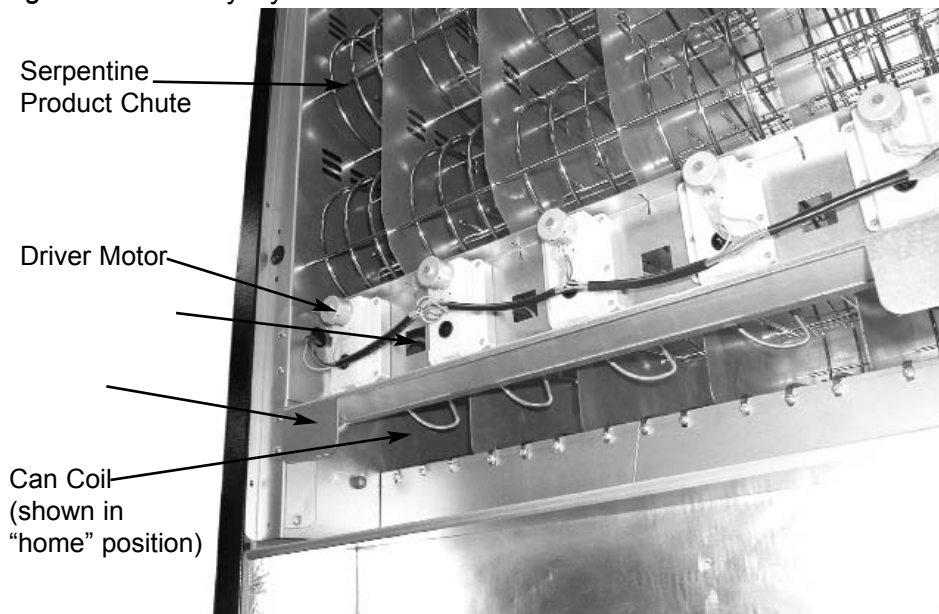

Figure 13 Serpentine Product Chute

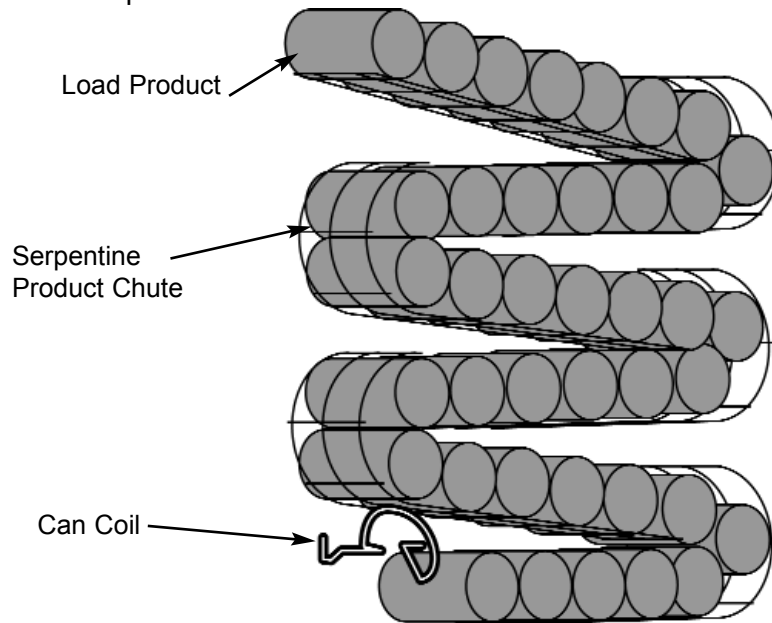
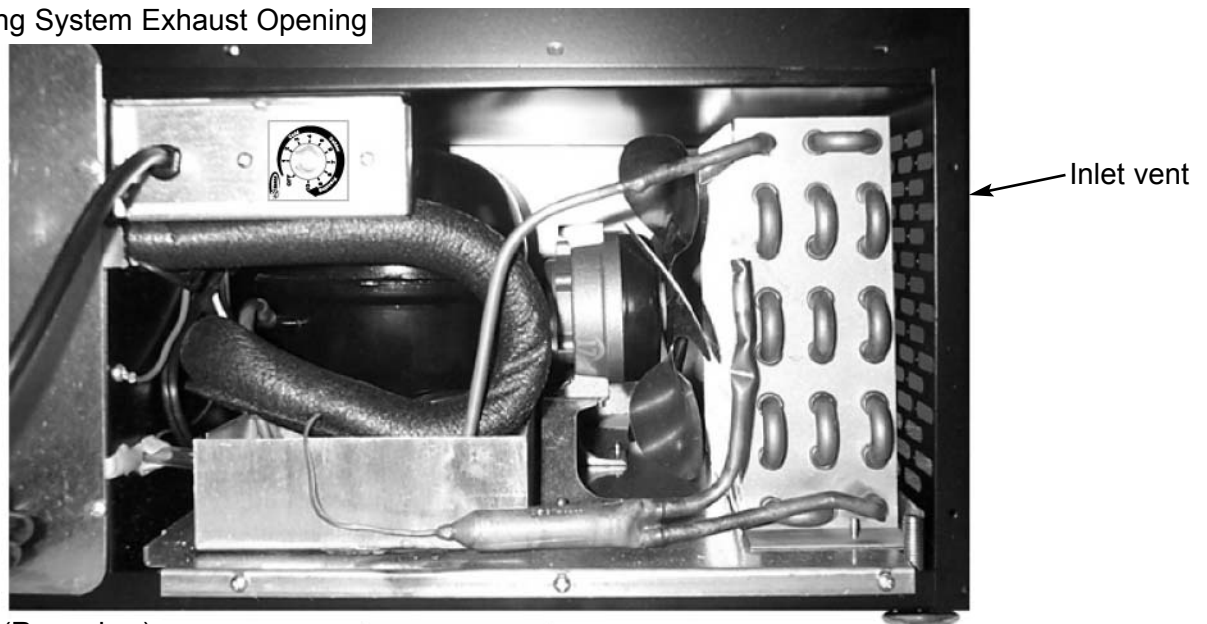
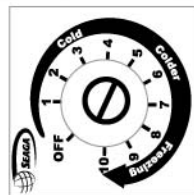

Figure 14 Cooling System Exhaust Opening



(Rear view)



product. **Note:** When the light flashes, there will be two cans of product remaining in the Serpentine Product Chute.

Q: The Compressor is running, but the vendor is too warm.

A: Turn the Adjustment Slot (1/8" at a time) clockwise to adjust to a colder temperature.

Make sure that the air flow is not restricted, there should be 6" (15 cm) of clearance on left and rear sides.

Thermostat may not be working properly.

Check for an air leak in the door seal.

Compressor may be undercharged with R134a.

Q: Why doesn't the Compressor cycle?

A: Thermostat may be set too cold. Turn the Adjustment Slot Counter (1/8" - 3 mm - at a time) counter-clockwise to a warmer temperature.  
Thermostat may not be working properly.  
Compressor may be undercharged with R134a.  
Compressor may be defective.

Q: Why is my Evaporator freezing?

A: Check and make sure the Air Circulation Fan is working.

Q: After removing and reinstalling or replacing the control board the motor count is wrong and the motors will not run.

A: Insure the proper orientation of the motor and home switch harnesses when plugging them back onto the control board. See Figure 3.

### **NOTES**