



Seaga Spiral



Operator's Manual

INTRODUCTION

Congratulations on the purchase of your spiral bulk vendor. This spiral bulk vendor has been designed to give you many years of dependable service. It requires little maintenance and is easy to set up and operate.

READ THIS MANUAL COMPLETELY

Your vendor is designed to operate simply and reliably, but to take full advantage of your vendor, please read this owner's manual thoroughly. It contains important information regarding installation and operations, as well as a brief troubleshooting guide.

EQUIPMENT INSPECTION

After you have received your vendor and have it out of the box, place it on a secure surface for further inspection. **Note:** Any damages that may have occurred during shipping must be reported to the delivery carrier immediately. Reporting damages and the seeking of restitution is the responsibility of the equipment owner. The factory is willing to assist you in this process in any way possible. Feel free to contact our Customer Care Department with any questions you may have on this process.

Once you have your vendor located, we suggest that you keep this manual for future reference, or you can view this manual online at www.seagamfg.com. Should any problems occur, refer to the section entitled "COMMON QUESTIONS AND ANSWERS". It is designed to help you quickly identify a problem and correct it.

MANUFACTURER'S WARRANTY

WHAT IS COVERED:

Manufacturer warrants TO THE ORIGINAL PURCHASER ONLY that each item of equipment manufactured is free from defects in material and workmanship under normal use and service. Manufacturer's obligation under this warranty shall be limited to repair or replacement, at our plant, of any parts of the equipment which shall, within one year of the date of shipment to the original purchaser, be demonstrated to be defective. The original purchaser may obtain repair or replacement of the equipment under this warranty by returning the defective item or entire vendor to the Manufacturer, freight pre-paid.

WHAT IS NOT COVERED:

Manufacturer's warranty obligations DO NOT EXTEND TO OR INCLUDE installation expenses, vandalism, or difficulties resulting from failure to operate equipment in accordance with Manufacturer's instructions under competent supervision and difficulties due to changes in vended products which are beyond the control of Manufacturer.

SPECIAL NOTE:

Manufacturer is not responsible for any loss of income due to a vending machine being out of service due to a warrantable item.

This warranty is in lieu of all other warranties, expressed or implied, including the warranty of merchantability and fitness or use, and of all other obligations or liabilities on Manufacturer's part. Manufacturer neither assumes, nor authorizes any other person to assume for it, any other liability in connection with the sale of equipment manufactured by itself. This warranty shall not apply to equipment manufactured or any part thereof which is subject to accident, negligence, alteration, abuse, misuse or damage in shipment. The term "original purchaser," as used in this warranty, shall be deemed to mean that person for whom the equipment is originally installed.

Manufacturer is not liable for any incidental, consequential or other damages of any kind whatsoever, directly or indirectly, arising from the use of the equipment whether based upon theories of contract negligence or tort.

Effective 9/01

For Technical Support & Service

Contact our Customer Care Dept.

8:30 a.m. - 4:00 p.m. CST. Mon thru Fri
800.444.1954 ext 160, Domestic
815.297.9500 ext 160, International
815.297.1758 Fax
email: customercare@seagamfg.com

For Parts

Contact our Parts Dept.

8:30 a.m. - 4:00 p.m. CST. Mon thru Fri
800.444.1954 ext 160, Domestic
815.297.9500 ext 160, International
815.297.1758 Fax
email: parts@seagamfg.com



Seaga Manufacturing, Inc.

700 Seaga Drive

Freeport, IL 61032 U.S.A.

Online: www.seagamfg.com

SB2200

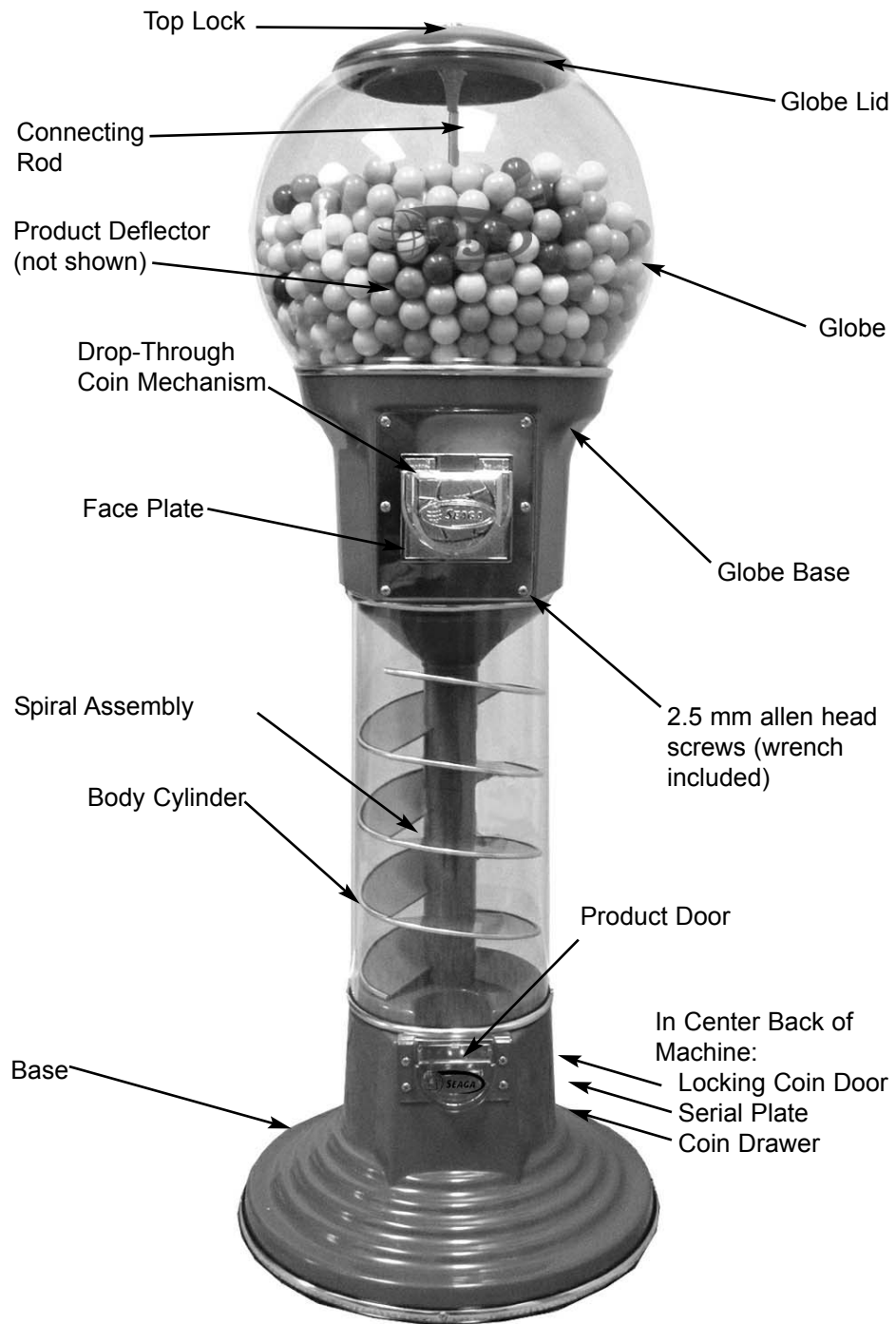

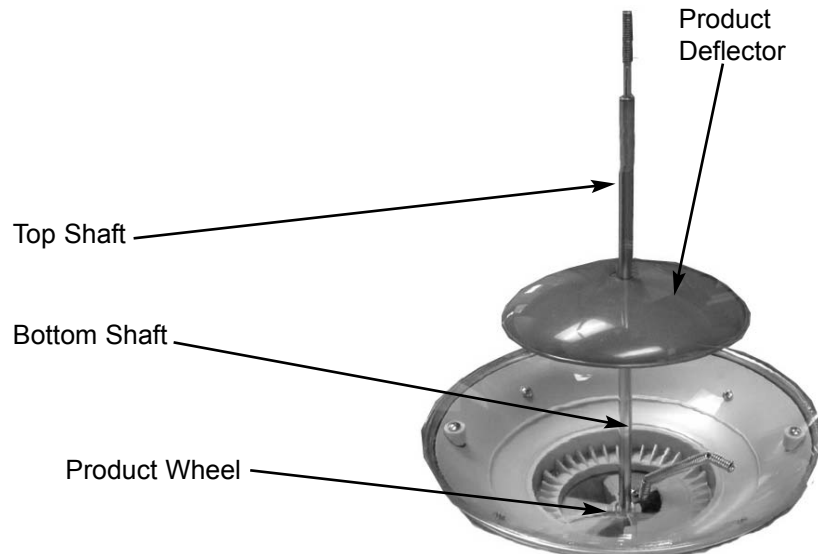

LOCKS

Your vendor has two (2) locks, one (1) on the Globe Lid and one (1) on the Coin Door. To unlock the top lock, insert the key and turn counter-clockwise until the lock releases the center post. You will be able to feel when the lid has been released and can be removed. To unlock the coin door, turn the key one-quarter turn clockwise.

To lock the Globe Lid, line up the lock housing with the Connecting Rod, line up the two notches on the top of the Globe with the "teeth" on the Globe Lid, turn key in clockwise and pull key out. **DO NOT OVER-TIGHTEN YOUR LOCK** - again, you will be able to feel when the top lid is secured.

DELIVERY SYSTEM

The spiral vendor comes standard with a product wheel suitable for maximum 1" product. If your product becomes melted it may be necessary to clean the wheel.

1.) To remove the product wheel:

A.) Unlock the top lock and remove the globe lid. Remove top shaft and product deflector.
Remove bottom shaft.

B.) Remove wheel housing screws (2) and lift off wheel housing to expose vend wheel. (Fig. 1)

C.) Product wheel can now be lift off for cleaning wheel housing.

The spiral vendor delivers the product down a product ramp. The spiral vendor will work best with product that is perfectly round - such as a gumball.

Special Note: Upon reassembly, make sure to center the product guide tab on the wheel housing over the product chute opening in the base (Fig. 1) Also, we suggest that you always partially fill the Globe with product and perform at least five (5) test vends.

Figure 1 Wheel Housing

Wheel Housing
Screws (2)

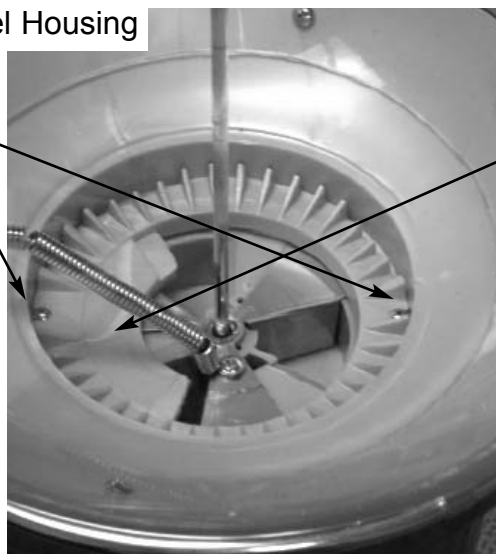

Product guide should
always be centered
over product chute
hole upon re-assembly

CAPACITY

Your spiral vendor holds approximately 1,450 one-inch gumballs, or approximately 30 lbs. The coin tray holds approximately 2000 quarters.

COIN MECHANISM

The Coin Mechanism (Page 2) can be removed by using the 2.5 mm Allen Wrench included in your parts pack to remove the six (6) allen head screws in the face plate (Fig. 2). Once the face plate is removed, the Coin Mechanism can now be pulled out and removed.

1. To Dismantle Coin Mechanism:

- A.) Remove Center Screw.
- B.) Remove Sprocket.
- C.) Remove three (3) Mounting Screws.
- D.) Pull Back Plate away from Face Plate.
- E.) Remove jammed coin.
- F.) Replace parts in steps A-D in reverse order.

COIN RETRIEVAL

You can retrieve coins from your vendor from the coin drawer located behind a locked door in the rear of the machine. Enter the rear of the vendor by unlocking Coin Door and removing the door itself. Accepted coins are stored in the coin drawer, but it is normal for some scattering to occur.

GENERAL NOTES

You may choose to fill the bottom cavity of your vendor with aquarium gravel, sand or other material to weigh the machine down. Unlock and remove the Coin Door and make sure the Coin Drawer is centered under the coin collection area. Spread gravel or sand around Coin Drawer, being careful to keep it centered under the coin collection area.

COMMON QUESTIONS AND ANSWERS

VENDING

Q: How does my spiral vendor actually Vend?

A: Your vendor is a gravity-feed bulk vendor. Gravity feeds the product to the bottom of the vendor. Maintaining fresh, non-melted product is essential.

Q: Can I always count on a 100% consistent vend?

A: It is recommended that you use products that are consistent in size, such as gumballs for example. Products consistent in size will not only vend down the ramp better, but also produce a more consistent vend.

Q: Does the globe need to be full to vend properly?

A: No. A selection will dispense as long as there is product that drops into the vend wheel.

Q: How do I remove product from the globe?

A: We recommend that you bring a clean container and something to scoop with when you service the machine. Scoop out product from the top into your clean container. Some product will remain, but this will remove the majority of the product.

Q: What do I do if product becomes "gummed up" in my vendor?

A: If your product is melted together, scoop out as much product as possible from the globe. Your product area can now be wiped out. For severe cases, the entire unit may need to be cleaned.

Special Note: The vendor must be absolutely dry before loading with product.

OPERATION

Q: Can I use tokens in my vendor?

A: Tokens can be used if they are the exact size and thickness as a quarter. Special mechanisms can be ordered from the Parts department.

Q: How many quarters will my coin box hold?

A: Your Vendor can hold 2000 quarters.

Q: Will slugs work in my Coin Mechanism?

A: As is with all bulk vending machines, the possibility of slugs passing through does exist. The size of the slug does need to be close to the same size as a quarter for it vend however.

Q: Will washers work in my Coin Mechanism?

A: The Coin Mechanism is equipped with a washer detector, located on the back, left side of the mechanism. This detection device will stop most washers, but is not guaranteed to stop them all.

Q: What do I do if my mechanism rotates backwards?

A: Remove mechanism and determine if the Hammer has not engaged the Ratchet Wheel. Check for possible loose screws.

Q: What do I do if my mechanism rotates fully with an incorrect coin or no coin?

A: Remove the mechanism as described in the Coin Mechanism section of this manual. First check to see if the screws on the back of the mechanism are tight. If the problem persists the Coin Detector and Coin Detector Spring may be loose or missing.

Q: Will my mechanism ever require lubrication? If so, how do I lubricate it?

A: Lubricate on an "as needed basis". To do so, you do not need to open the machine, simply place a quarter in the mechanism and rotate the handle $\frac{1}{4}$ turn. Place a small drop of lubricating oil on each side of the exposed Coin Wheel and complete the handle rotation. A couple of rotations may be necessary to "loosen" up the turning of the mechanism.

MAINTENANCE

Q: How do I clean the outside of my Vendor?

A: A non lint depositing rag or towel and a little window cleaner will be sufficient to clean the outside of your Vendor. Make sure the rag is a clean, white, all cotton rag so you do not scratch your vendor. A clean well-stocked machine is an inviting machine!

NOTE: Do not spray window cleaner directly on any decals and never use harsh chemicals on the machine.

NOTES

COIN MECHANISM Figure 4 Coin Mechanism Exploded View

TV115

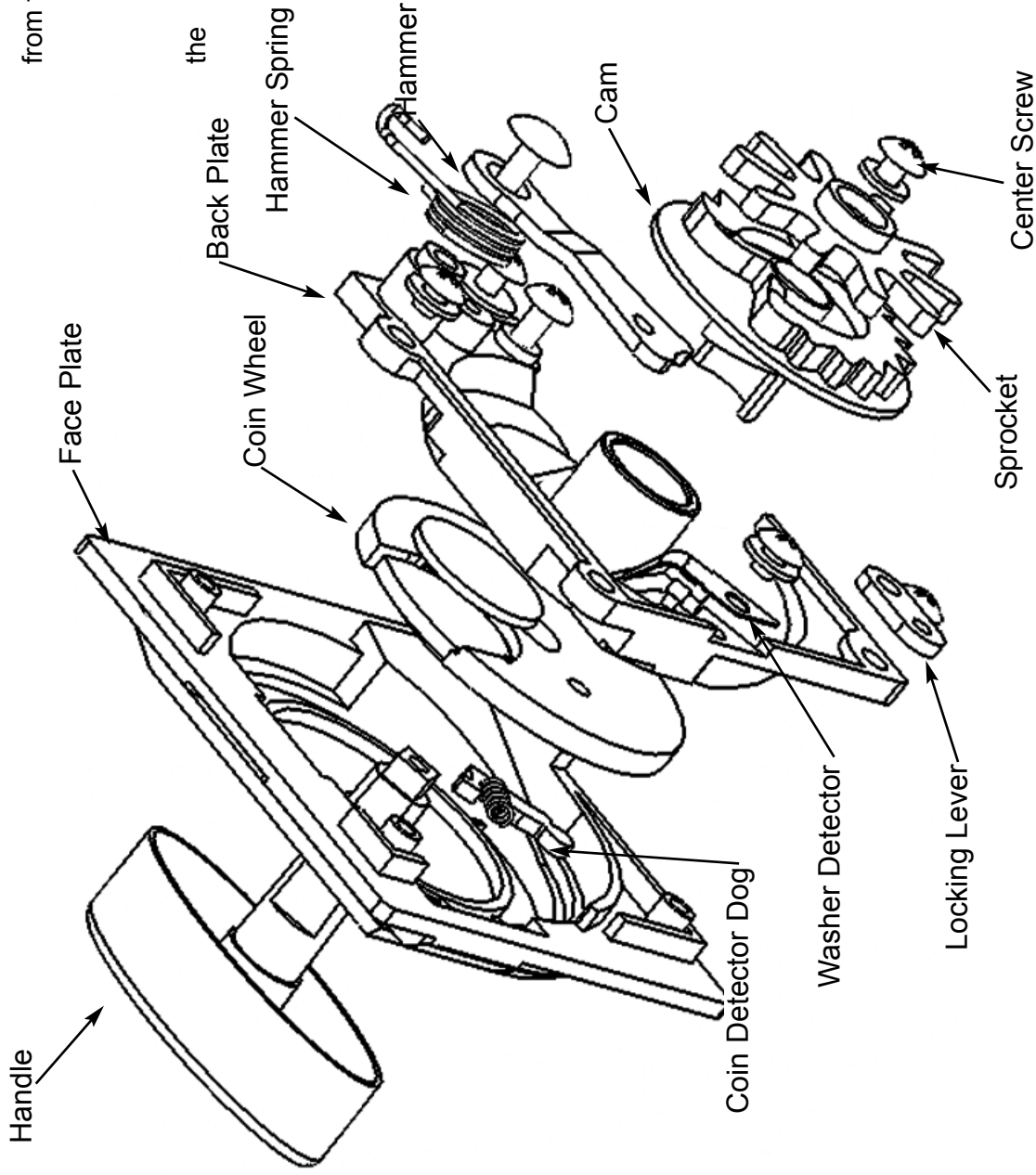

1. To Replace Mech. Handle:

- A.) Turn the Hammer clockwise up and away from the Cam.
- B.) Remove Center Screw.
- C.) Remove Sprocket, washers and Cam.
- D.) Pull the Mech. Handle out from the front of the mechanism.
- E.) Line up new Mech Handle and push into the mechanism.
- F.) Align the Cam with finger pointing upward.
- G.) Replace washers.
- H.) Replace Sprocket.
- I.) Replace Screw and tighten.
- J.) Return Hammer to its starting position.

Illustration for Adjustment & Maintenance Use Only. Coin Mechanism Parts Not Sold Separately.